

OPERATION MANUAL

HYDRAULIC CEMENT PLUGS MILLING UNIT
(HCPM) - 80 To.

2012

 S.C. CONFIND S.R.L. Câmpina	OPERATION MANUAL HYDRAULIC CEMENT PLUGS MILLING UNIT (HCPM) – 80 To.	Code: P4356-MU	Date: November 2012
		File: 2 / 51	Revision: 0

2012

SUMMARY

1. Description.....	3
2. Technical parameters.....	5
3. Components.....	6
4. Transport instructions, site installation and operating.....	27
5. Instructions for maintenance and repairing.....	36
6. Spare parts list	41
7. Warranty.....	43
8. Work safety.....	44
9. Environment protection.....	47
Annexes.....	48

 S.C. CONFIND S.R.L. Câmpina	OPERATION MANUAL HYDRAULIC CEMENT PLUGS MILLING UNIT (HCPM) – 80 To.	Code: P4356-MU	Date: November 2012
		File: 3 / 51	Revision: 0

1. DESCRIPTION

1.1. The product name

Hydraulic cement plugs milling unit (HCPM) 80 to.

1.2. Applicability

With this installation the following operations can be performed:

- Milling and washing of the sand and cement plugs from the liner perforated;
- Milling of the cement plugs inside the casings, the drill pipes and tubing, the packers, string corrections;
- Internal cutting of the casings and tubing;
- Different operations of fishing and coring;
- Make up - break out operations;
- Field excavations

1.3. Description and functioning

The HCPM is located on a skid and consists of a pressure group, swivel, control console, hydraulic hoses and oil tank. Hydraulic energy developed by the hydraulic pump is converted into a rotating motion by the swivel.

Actuation of the swivel is made from the control console, which is located on the skid, through high pressure hydraulic hoses and the flow required for the hydraulic actuation comes from a hydraulic pump that sucks oil from a hydraulic tank of 300 liters. The pump is driven by a diesel engine.

The Cummins engine has a diesel fuel circuit (supply and return) in a 200 liter tank. The electric part of the electric motor includes the power supply of the starting electromotor from two batteries in series for 24V and 12V and the power supply of the indicator board devices.

The swivel is suspended in the workover rig travelling block and guided by two cables of $\Phi 22$ mm, mounted on the mast (anti-rotation device). The cables are part of the milling unit equipment for the workover rig AM12/40 or AM12/50 or belonging to the beneficiary in case of other workover rigs.

It allows rotation of the string with variable rotations and torques in both directions and carrying out the fluid circulation, taking over the role of the swivel and the rotary table.

The 80 to swivel is a hydrostatic driven mechanism that allows rotation of the rod seal and ensures circulation, at the following operations:

- milling and washing cement and sand plugs in the wells string casing;
- milling the cement plugs inside the wells string casing and the packers tubing, casing corrections;
- interior cutting of the tubing;
- different operations of fishing and coring;
- make up - break out operations;
- field excavations (limited).

The hydraulic actuation ensures the transmission of the torque at the working drill string, changing the rotation direction, speed variation or the torque.

The functions of the swivel are:

SC CONFIND SRL	Adresa : 105600, Câmpina, str. Progresului, nr. 2, jud. Prahova, Romania Tel/Fax : 0244333160 / 0244374719 ; E-mail : confind@confind.ro
----------------	---

 S.C. CONFIND S.R.L. Câmpina	OPERATION MANUAL HYDRAULIC CEMENT PLUGS MILLING UNIT (HCPM) – 80 To.	Code: P4356-MU	Date: November 2012
		File: 4 / 51	Revision: 0

- supporting the drill string, drill pipe and ensuring its rotation;
- drive of drilling fluid under pressure from the fixed-loader through the flexible hose to the working drill string.

The swivel consists of two groups of parts: the first group is composed from stationary parts in the hook and the second group consists of rotary parts in motion.

The swivel body is one of the stationary part of the swivel in which the main bearing is fixed together with the swivel bails. At the upper side, the body is closed by a cover which is fitted with a sealing system of the oil bath; over this system is assembled the lantern, which has at the upper side a flange for fixing the Swivel neck, which makes the connection with the rotary hose. Also the body is attached at the bottom with the swivel driving system, consisting of a two-speed gearbox, on which two hydraulic motors are mounted.

The spindle is one of the rotating parts of the swivel, supported by the main bearing and it is provided with the passing bore for the drilling fluid. The spindle has at its bottom side the taper thread for the connection with the kelly valve. The connection between the upper side of the spindle and the Swivel neck is made through the wash pipe system. To ensure unscrewing of the kelly valve from the spindle during left-right rotation the spindle is fitted with a safety coupling.

The Swivel neck ensures the connection of the rotary hose.

The two-stage reduction gear has a robust and compact construction, of its housing are supported the hydraulic motors with bent body and axial pistons.

The swivel is equipped with a retrieval system of the torque reaction consisting of two arms guided by two cables of Ø22 from the anti-rotation device.

The anti-rotation device is destined to undertake the torque reaction of the swivel CHM 80 to. The anti-rotation device is included in the Hydraulic cement plugs milling unit and it is mounted on AM12/50 or AM12/40 Workover Rig.

The anti-rotation device is presented separately.

Whole assembly formed of the pressure group, swivel, control panel, hydraulic hoses, oil tank, etc., is mounted on a skid.

Subassemblies location on the frame is made in order to allow easy removal for possible interventions and remediation.

For transport, the system is equipped with a lifting device for loading and unloading in the transportation means.

The temperature range in which the milling unit operates at rated parameters is from -29 ° C to +45 ° C.

SC CONFIND SRL	Adresa : 105600, Câmpina, str. Progresului, nr. 2, jud. Prahova, Romania
	Tel/Fax : 0244333160 / 0244374719 ; E-mail : confind@confind.ro

 S.C. CONFIND S.R.L. Câmpina	OPERATION MANUAL HYDRAULIC CEMENT PLUGS MILLING UNIT (HCPM) – 80 To.	Code: P4356-MU	Date: November 2012
		File: 5 / 51	Revision: 0

2. TECHNICAL PARAMETERS

CARACTERISTICS	Value	UM
Maximum static load of the CHM	100	to
Maximum live load (in rotation)	80	to
Maximum flow pressure	340	bar
Minimum passing diameter	52	mm
Connecting thread Swivel neck- Rotary Hose	2 in	LP
Connecting thread Spindle-Washer	3.1/2 in IF	right
Maximum pressure in the hydraulic system	290	bar
Flow in the hydraulic system	280	l/min
Maximum rotary bending	800	kgfm
Speed at the maximum rotary bending	90	rot/min
Maximum speed	140	rot/min
Torque at maximum speed	500	kgfm
Ambient temperature	-29°C...+45°C	
Hydraulic oil working temperature	-10°C...+80°C	
Diameter of the hose connection	1 1/4 in x 350 bar	
Direction of rotation	Left/right	
Type of actuation	parallel	
Transport dimensions of the skid	length 5460	mm
	width 2000	mm
	height 1990	mm
Oil tank capacity	350	l
Oil type	H46A	
Diesel engine: CUMMINS QSB 4.5 Tier III Stage III		
Power	160CP/2200rpm	
Torque	624Nm/1500rpm	
Average diesel consumption	310	g/CP·h
Main hydraulic pump	A17VO 080	
Hydraulic engines	A2FM80	
Oil bath capacity of the axial bearing	10	l
Oil type	T90EP2	
Oil bath capacity of the gearbox	10	l
Oil type	T90EP2	

 S.C. CONFIND S.R.L. Câmpina	OPERATION MANUAL HYDRAULIC CEMENT PLUGS MILLING UNIT (HCPM) – 80 To.	Code: P4356-MU	Date: November 2012
		File: 6 / 51	Revision: 0

3. COMPONENTS

The list of components for the hydraulic cement plugs milling unit 80 to, code: P4356-00 is presented in the table 1:

Table 1

Item	Subassembly	No. drawing or STAS	Pcs.
1	Frame	P4356-01.00.00	1
1.1.	Lifting system Connection cable with 4 branches and shackles G-3153/3.25 to	P3591-01.37.00	1
2	Cummins engine unit 160CP/2200rpm; Max. Torque 624Nm/1500rpm	QSB 4,5-C160	1
3	Pump drive system	P4356-03.00	1
4	Swivel	P4356-04.00.00	1
5	Swivel support	P3591-05.00	1
6	Hydraulic installation	P4356-06.00	1
7	Hydraulic oil reservoir	P4356-07.00	1
8	Diesel reservoir	P4356-08.00	1
9	Engine power installation	P3591-09.00	1
10	Supply and drainage hose drum	P4356-10.00	1
11	Swivel frame	P3591-17.00	1
12	Set of guards	P4356-12.00	1
13	Hydraulic panel	P4356-13.00	1
14	Tag	P4356-15	1
15	Anti-rotation device (System for torque reaction taking-up on AM12/50)	P4400-00	1
16	Monitoring installation	P4356-17.00	1



S.C. CONFIND S.R.L.
Câmpina

OPERATION MANUAL
HYDRAULIC CEMENT PLUGS
MILLING UNIT (HCPM) – 80 To.

Code:
P4356-MU

Date:
November 2012

File: 7 / 51

Revision: 0

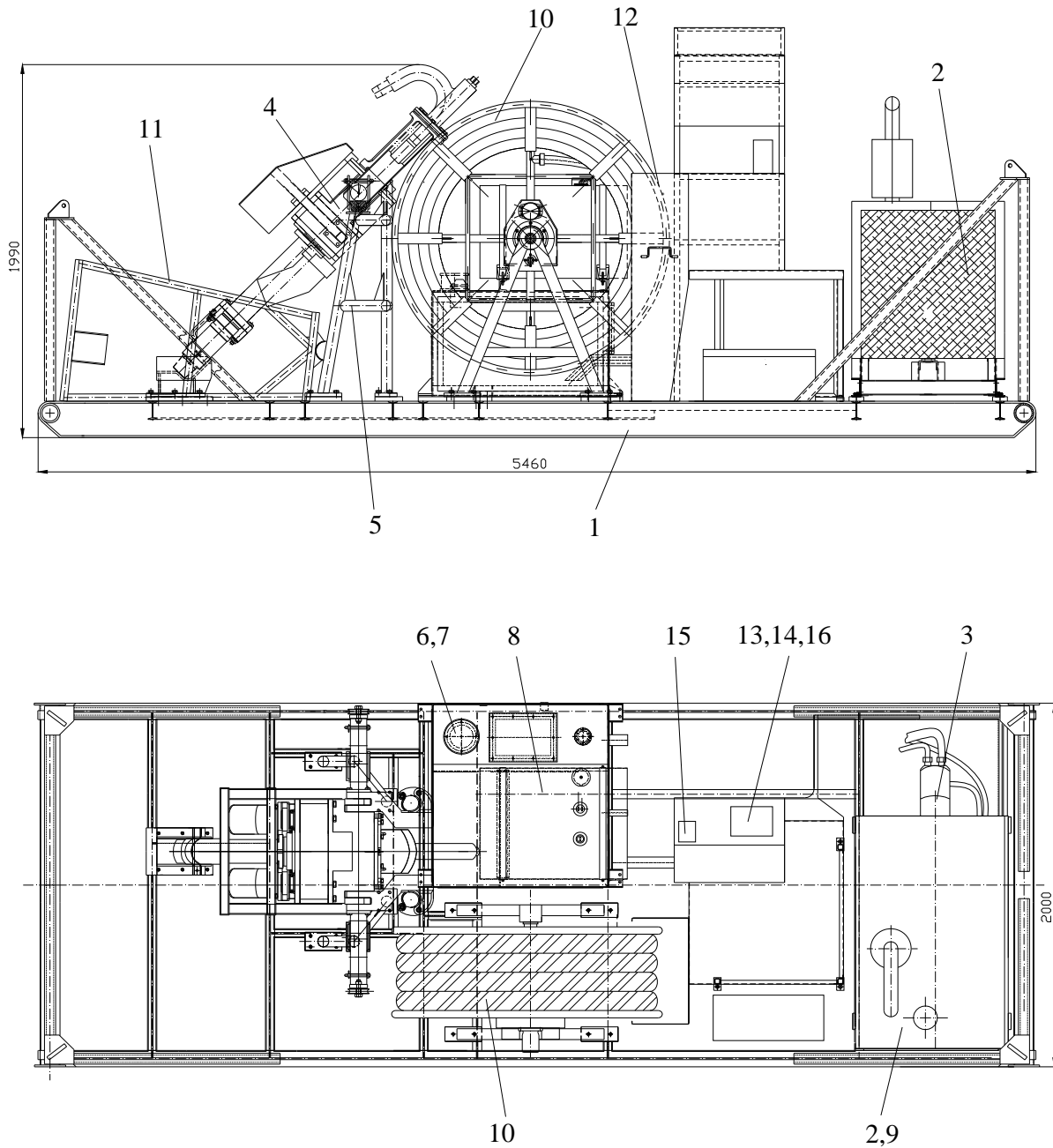

Fig.1 Overview



S.C. CONFIND S.R.L.
Câmpina

OPERATION MANUAL
HYDRAULIC CEMENT PLUGS
MILLING UNIT (HCPM) – 80 To.

Code:
P4356-MU

Date:
November 2012

File: 8 / 51

Revision: 0

DIAGRAMA TURATIE-MOMENT CHM80

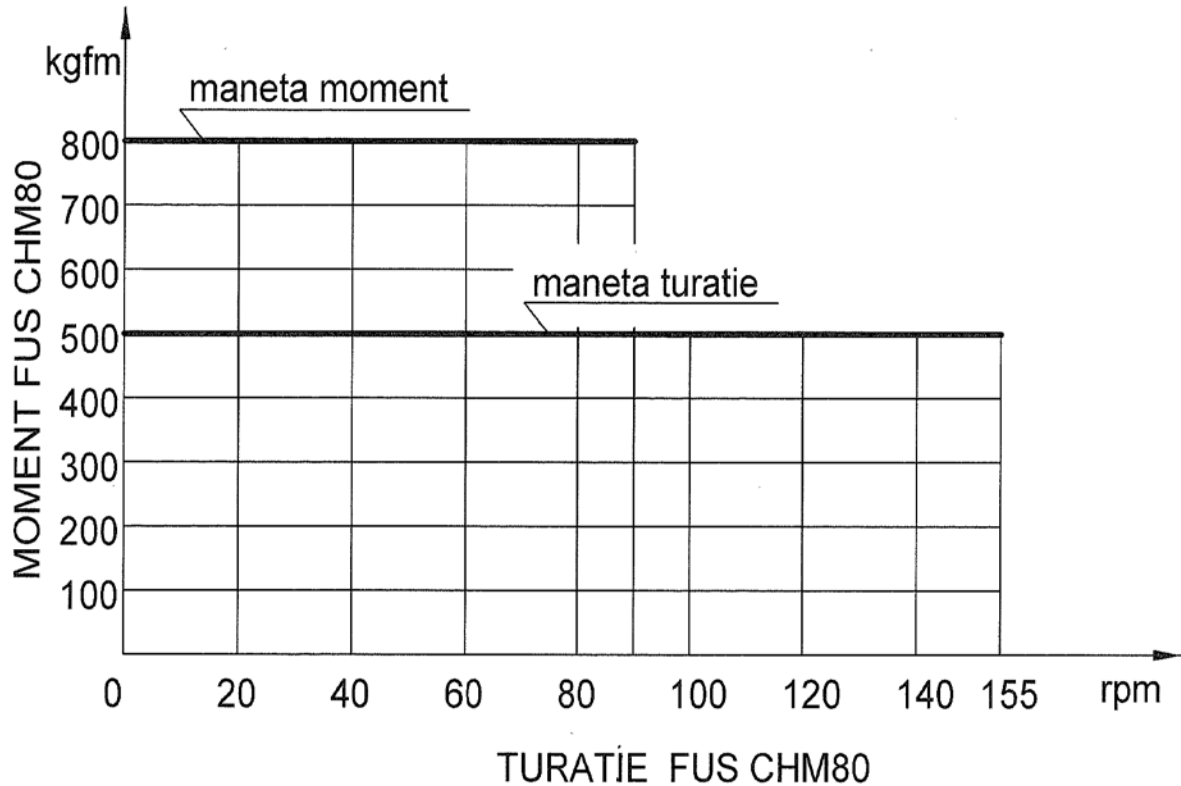



S.C. CONFIND S.R.L.
Câmpina

OPERATION MANUAL
HYDRAULIC CEMENT PLUGS
MILLING UNIT (HCPM) – 80 To.

Code:
P4356-MU

Date:
November 2012

File: 9 / 51

Revision: 0

SWIVEL

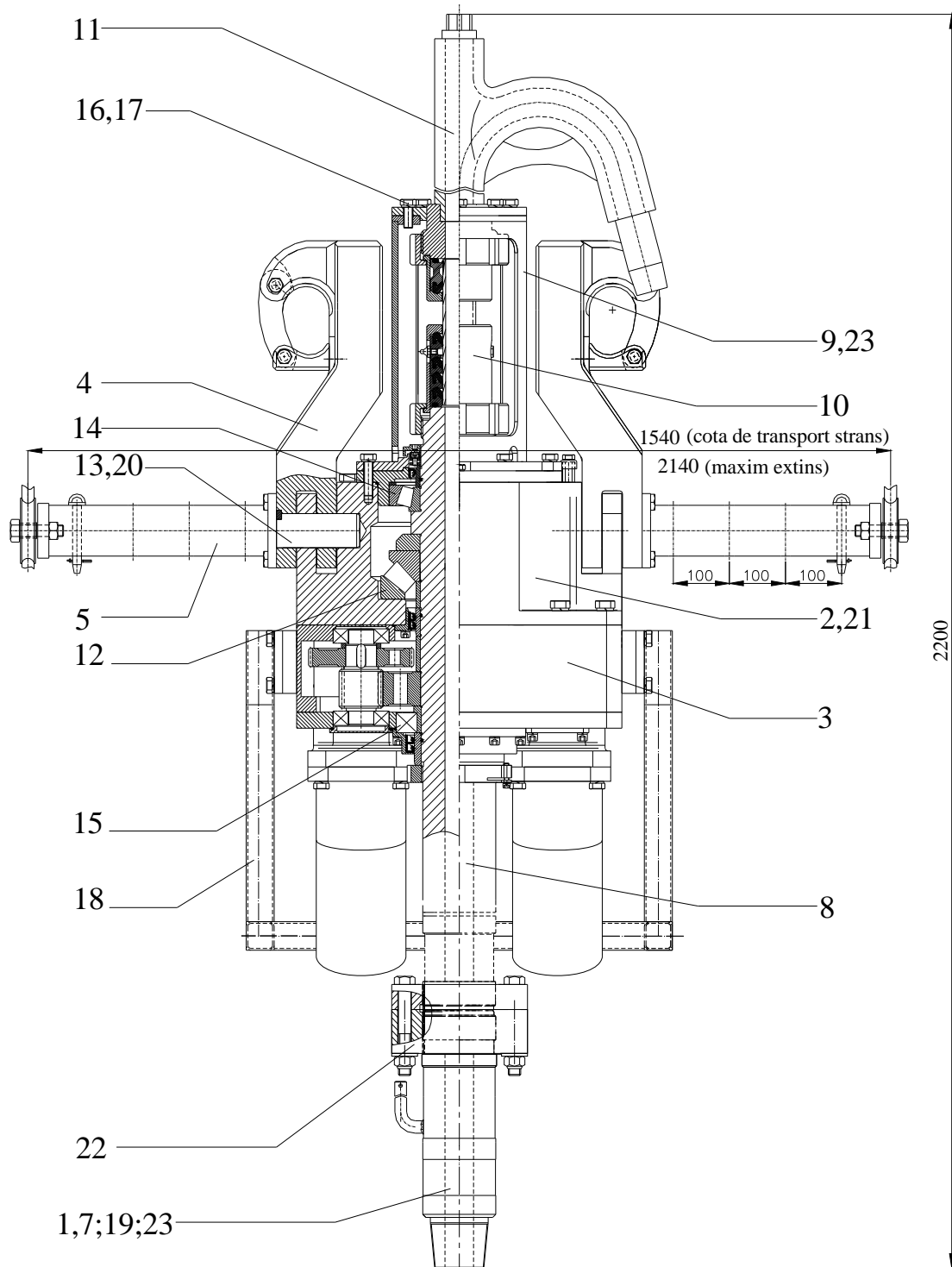



Fig.2 Swivel

 S.C. CONFIND S.R.L. Câmpina	OPERATION MANUAL HYDRAULIC CEMENT PLUGS MILLING UNIT (HCPM) – 80 To.	Code: P4356-MU	Date: November 2012
		File: 10 / 51	Revision: 0

Swivel components, code: P4356-04.00.00

Table 2

Item	Subassembly	No. drawing or STAS	Pcs.
1	Plug 3 1/2 IF		1
2	Body CHM80	P3591-04.02.00	1
3	Gearbox	P4356-04.03.00	1
4	Swivel bail CH80	P3591-04.04.00	2
5	Guiding system	P3591-04.05.00	2
7	Kelly valve ** Optionally – at request	P3591-04.07.00-DR	1
8	Spindle CHM80	P3591-04.08.00	1
9	Lantern	P3591-04.09.00	1
10	Washing pipe system	P3591-04.10.00	1
11	Swivel neck assembly 2x350	P3591-04.11.00	1
12	Bearing 140x280x85	29428E	1
13	Bolt	P3591-04.13.00	2
14	Bearing 140x250x45.75	30228A	1
15	Bearing 150x225x35	NU1030M	1
16	Screw M16x40	SR ISO 4017:2002	8
17	Spring washer MN16	SR 7666-2/1994	8
18	Protection system CHM	P4356-04.18.00	1
19	Kelly valve	P3591-04.07.00-STG	1
20	Plug M20x1,5	DIN908	2
21	Label CHM80	P3591-04.21	1
22	Kelly valve blockage	P3591-04.22.00	1
23	Shackle	P3591-04.23.00	1



S.C. CONFIND S.R.L.
Câmpina

OPERATION MANUAL
HYDRAULIC CEMENT PLUGS
MILLING UNIT (HCPM) – 80 To.

Code:
P4356-MU

Date:
November 2012

File: 11 / 51

Revision: 0

Wash pipe system

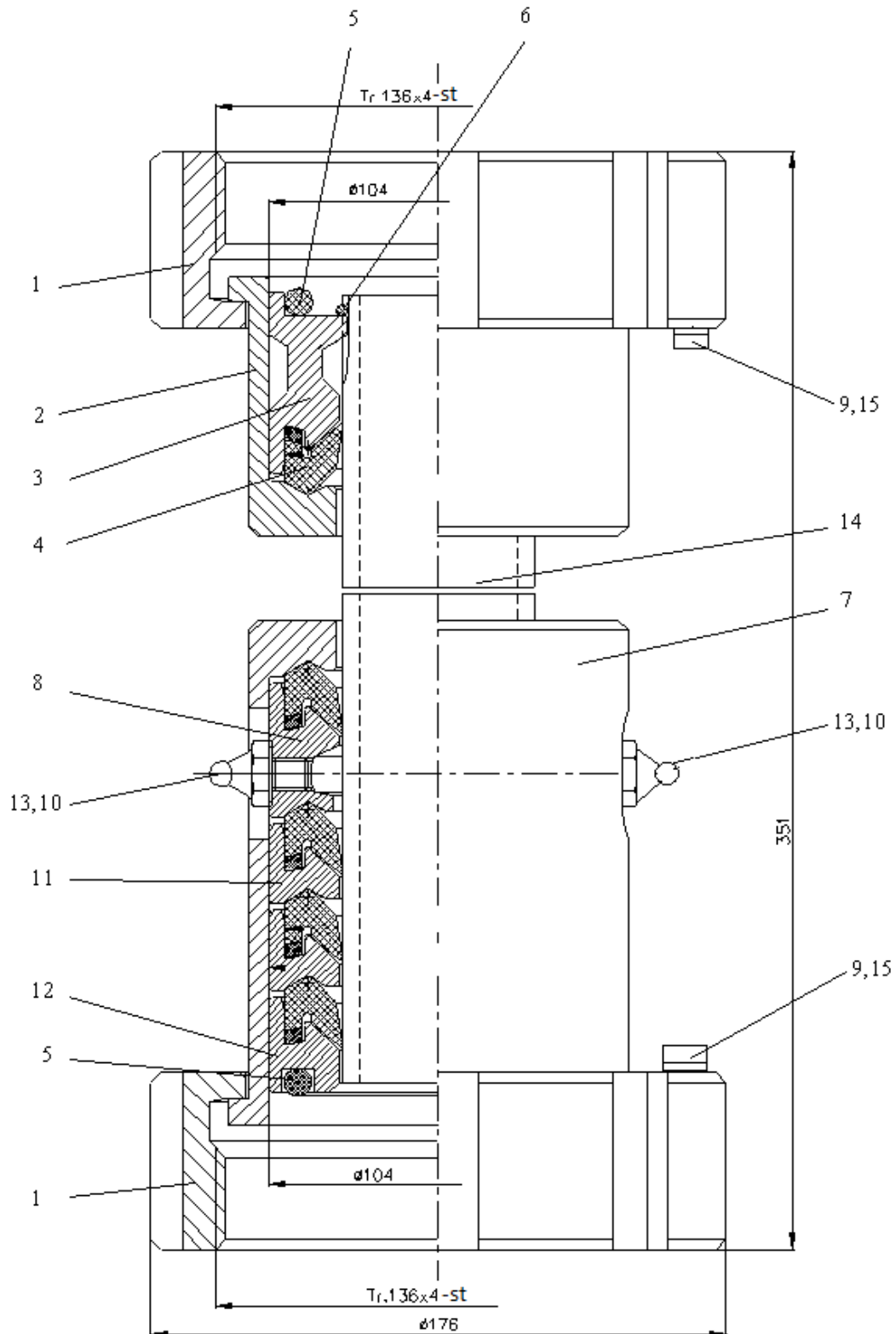



Fig.3 Wash pipe assembly

 S.C. CONFIND S.R.L. Câmpina	OPERATION MANUAL HYDRAULIC CEMENT PLUGS MILLING UNIT (HCPM) – 80 To.	Code: P4356-MU	Date: November 2012
		File: 12 / 51	Revision: 0

Components for washing pipe assembly, code: P3591-04.10.00

Table 3

Pos.	Subassembly	No. drawing or STAS	Pcs.
1	Sealing package nut	P3591-04.10.01	2
2	Upper can	P3591-04.10.02.00	1
3	Upper ring	P3591-04.10.03	1
4	Gasket CH80	P3591-04.10.04	5
5	O-Ring IO 77x8.4	STAS 7320-2/80	2
6	Safety ring A1-60	STAS 8436-69	1
7	Lower can	P3591-04.10.07.00	1
8	Lubricating ring	P3591-04.10.08	1
9	Screw M10x55	DIN 912	2
10	Copper washer	3521501016	2
11	Intermediate Ring	P3591-04.10.11	2
12	Lower Ring	P3591-04.10.12	1
13	Lubricator type A M10x1	STAS 1116-88	2
14	Wash pipe	P3591-04.10.14	1
15	Spring washer MN10	DIN 127	2



S.C. CONFIND S.R.L.
Câmpina

OPERATION MANUAL
HYDRAULIC CEMENT PLUGS
MILLING UNIT (HCPM) – 80 To.

Code:
P4356-MU

Date:
November 2012

File: 13 / 51

Revision: 0

SW
IVEL NECK ASSEMBLY 2x350

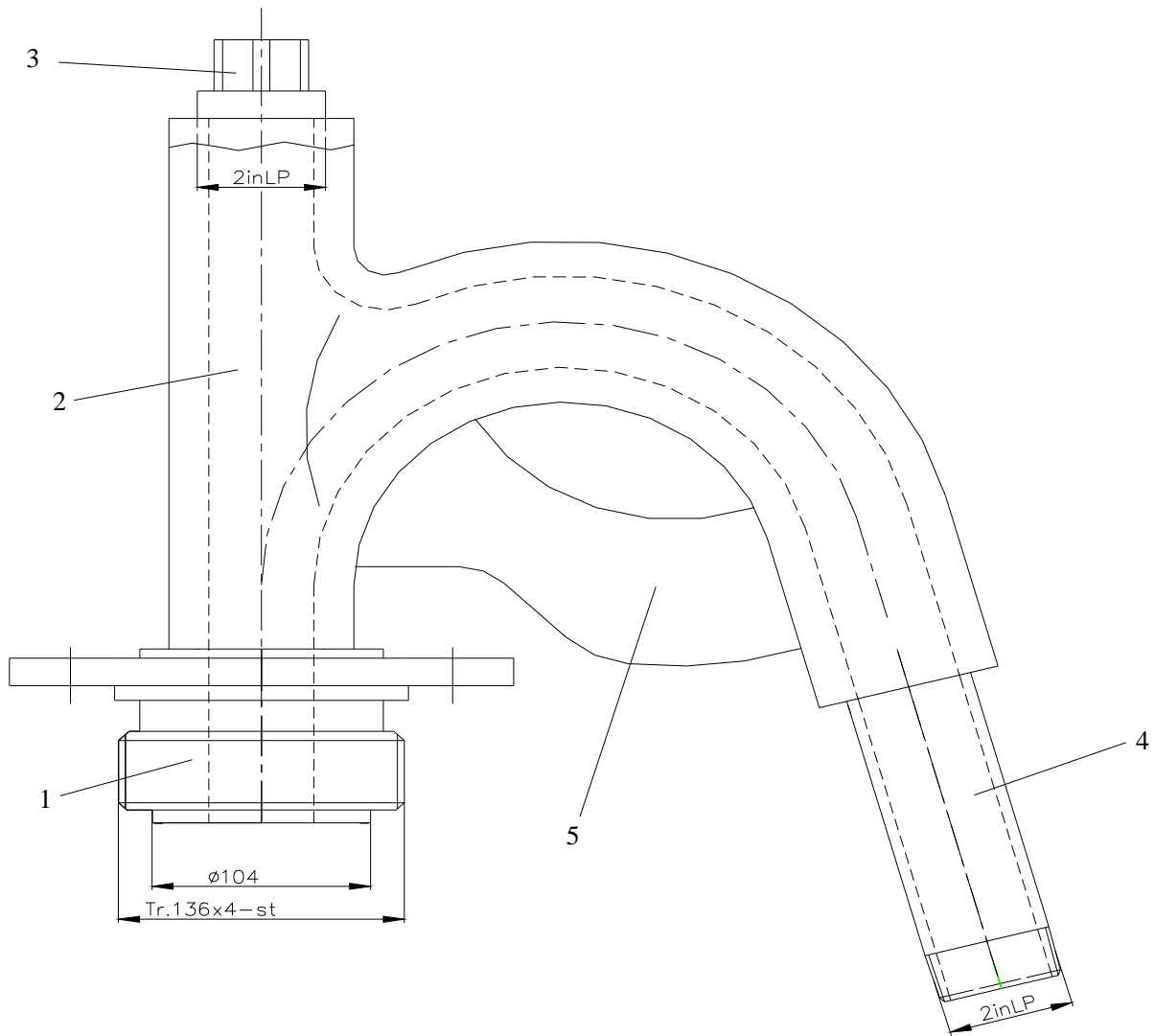



Fig.4 Swivel assembly 2x350

 S.C. CONFIND S.R.L. Câmpina	OPERATION MANUAL HYDRAULIC CEMENT PLUGS MILLING UNIT (HCPM) – 80 To.	Code: P4356-MU	Date: November 2012
		File: 14 / 51	Revision: 0

Components for the swivel neck assembly 2inx350 code: P3591-04.11.00

Table 4

Pos.	Subassembly	No. drawing or STAS	Pcs.
1	Swivel neck supporting flange	P3591-04.11.01.00	1
2	Swivel neck	LI-2-350-LP	1
3	Plug 2in LP	P3591-04.11.03	1
4	Nozzle 2LP-2LP	P4581	1
5	Rib	P3591-04.11.05	1



S.C. CONFIND S.R.L.
Câmpina

OPERATION MANUAL
HYDRAULIC CEMENT PLUGS
MILLING UNIT (HCPM) – 80 To.

Code:
P4356-MU

Date:
November 2012

File: 15 / 51

Revision: 0

GEARBOX

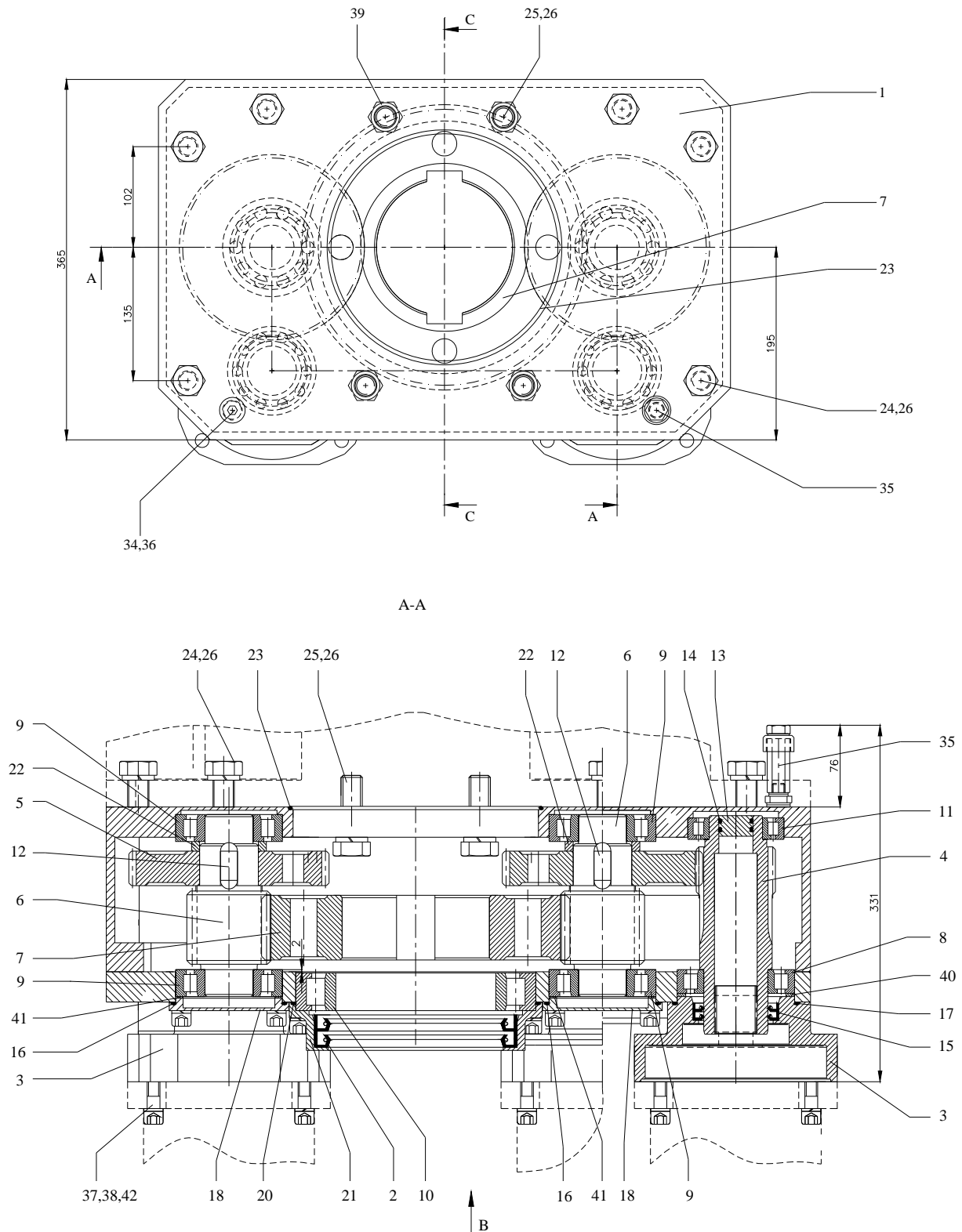



S.C. CONFIND S.R.L.
Câmpina

OPERATION MANUAL
HYDRAULIC CEMENT PLUGS
MILLING UNIT (HCPM) – 80 To.

Code:
P4356-MU

Date:
November 2012

File: 16 / 51

Revision: 0

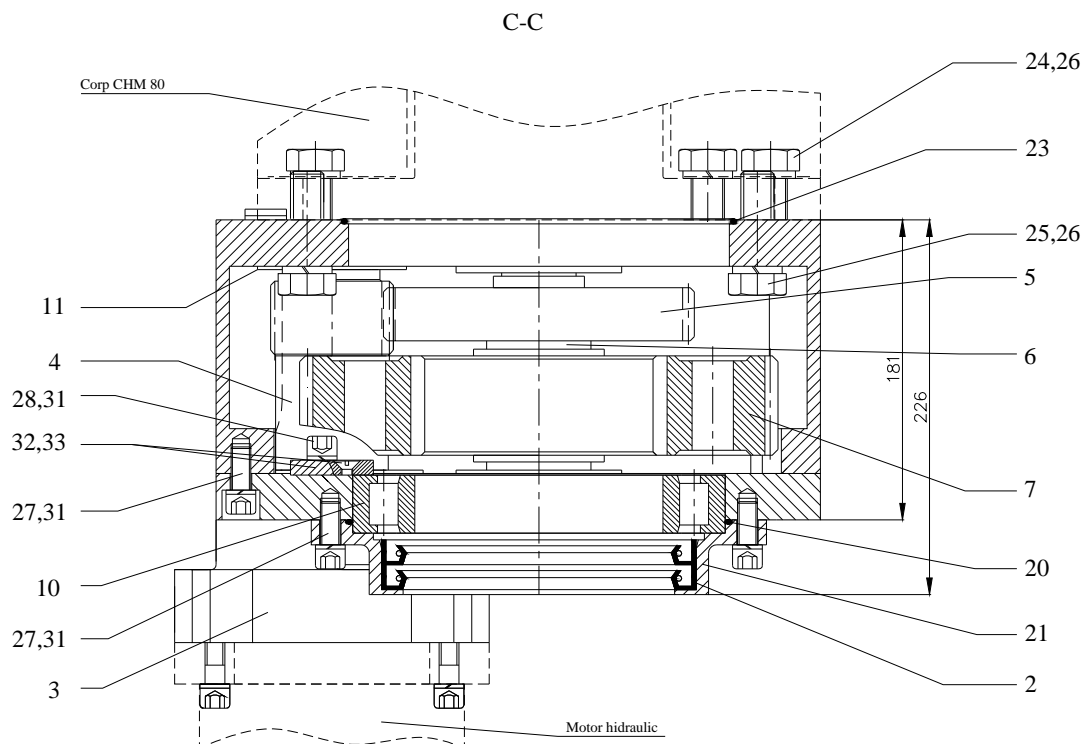
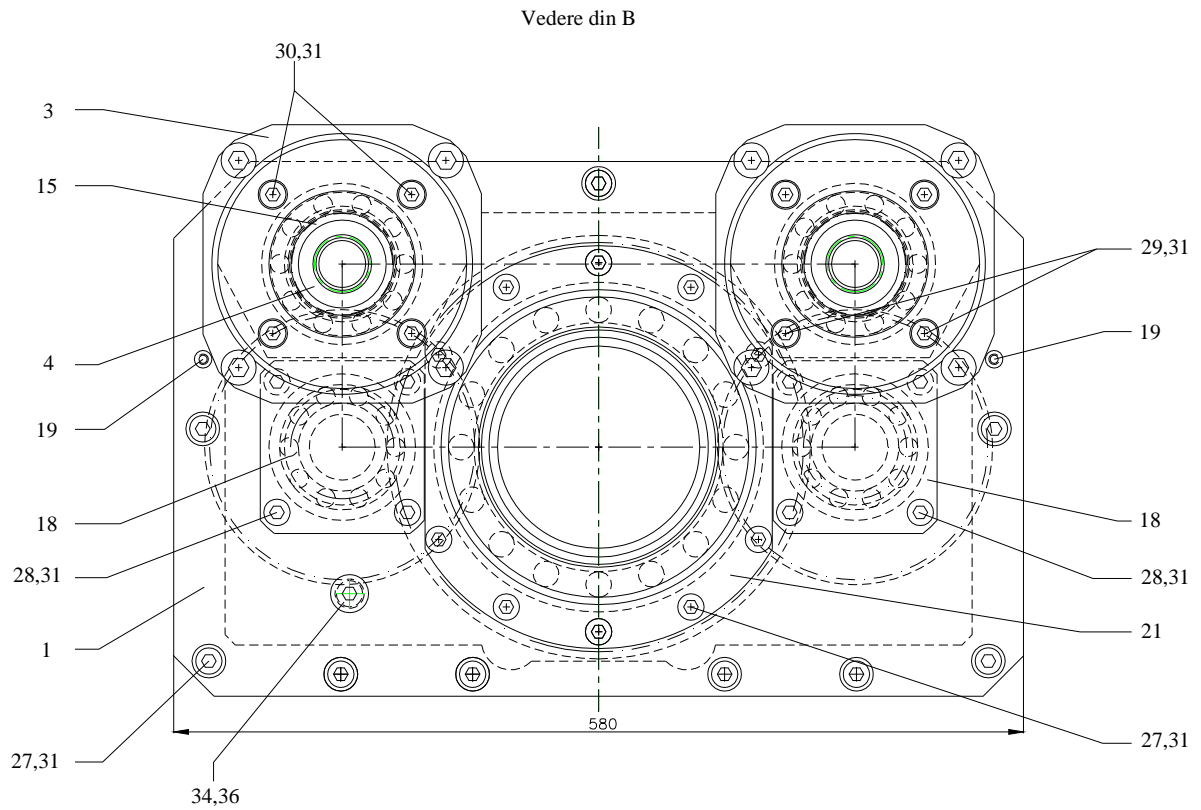



Fig. 5-8 Gearbox

 S.C. CONFIND S.R.L. Câmpina	OPERATION MANUAL HYDRAULIC CEMENT PLUGS MILLING UNIT (HCPM) – 80 To.	Code: P4356-MU	Date: November 2012
		File: 17 / 51	Revision: 0

Gearbox components, code: P4356-04.03.00

Tabel 5

Pos.	Subassembly	No. drawing or STAS	Ocs.
1	Gearbox body	P3591-04.03.01.00	1
2	Seal Oil A160x190x15	STAS 7950/2-87	2
3	Engine supporting flange	P4356-04.03.03	2
4	Inlet pinion	P3591-04.03.04	2
5	Gear wheel 1	P3591-04.03.05	2
6	Intermediate pinion shaft	P3591-04.03.06	2
7	Gear wheel 2	P3591-04.03.07	1
8	Bearing Ø60x Ø110x22	NJ212E	2
9	Bearing Ø45x Ø100x25	NJ309EM	4
10	Bearing Ø150x Ø225x35	NU1030M	1
11	Bearing Ø50x Ø90x20	NJ210E	2
12	Key 16x10x28	P3591-04.03.12	4
13	Plug	P3591-04.03.13	2
14	O-Ring 29.5x3	STAS 7320/1-85	4
15	Oil retainer ring A60x80x8	STAS 7950/2-87	4
16	O-Ring 109.5x3	STAS 7320/1-85	2
17	O-Ring 99.5x3	STAS 7320/1-85	2
18	Lower cover 1	P3591-04.03.18	2
19	Taper pin Ø15x46	P3591-04.03.19	2
20	O-Ring 225x3	STAS 7320/1-85	1
21	Lower cover 2	P3591-04.03.21	1
22	Spacer ring	P3591-04.03.22	2
23	O-Ring 229.5x3	STAS 7320/1-85	2
24	Screw M20x45	SR ISO 4017:2002	6
25	Screw M20x55	SR ISO 4017:2002	4
26	Spring washer MN20	SR 7666-2/1994	10
27	Screw M12x30	SR ISO 4017:2002	21
28	Screw M12x25	SR ISO 4017:2002	10
29	Screw M12x40	SR ISO 4017:2002	4
30	Screw M12x65	SR ISO 4017:2002	4
31	Washer MN12	SR 7666-2/1994	39
32	Key 9x50x200	P3591-04.03.32	1
33	Screw M8x16	STAS 2571-90	2
34	Plug M20x1.5	STAS 5606-80	2
35	Vent	P3591-04.02.06.00	1
36	Copper washer M20	3521502026	2
37	Screw M12x40	SR EN ISO 4762:2002	8
38	Spring washer MN12	SR 7666-2/1994	8
39	O-Ring 22.5x3	STAS 7320/1-85	4
40	Adjusting ring Ø110	P3591-04.03.40	2
41	Adjusting ring Ø100	P3591-04.03.41	2
42	Galvanized wire Ø1-450	P4356-04.03.42	24



HYDRAULIC FLOW CHART

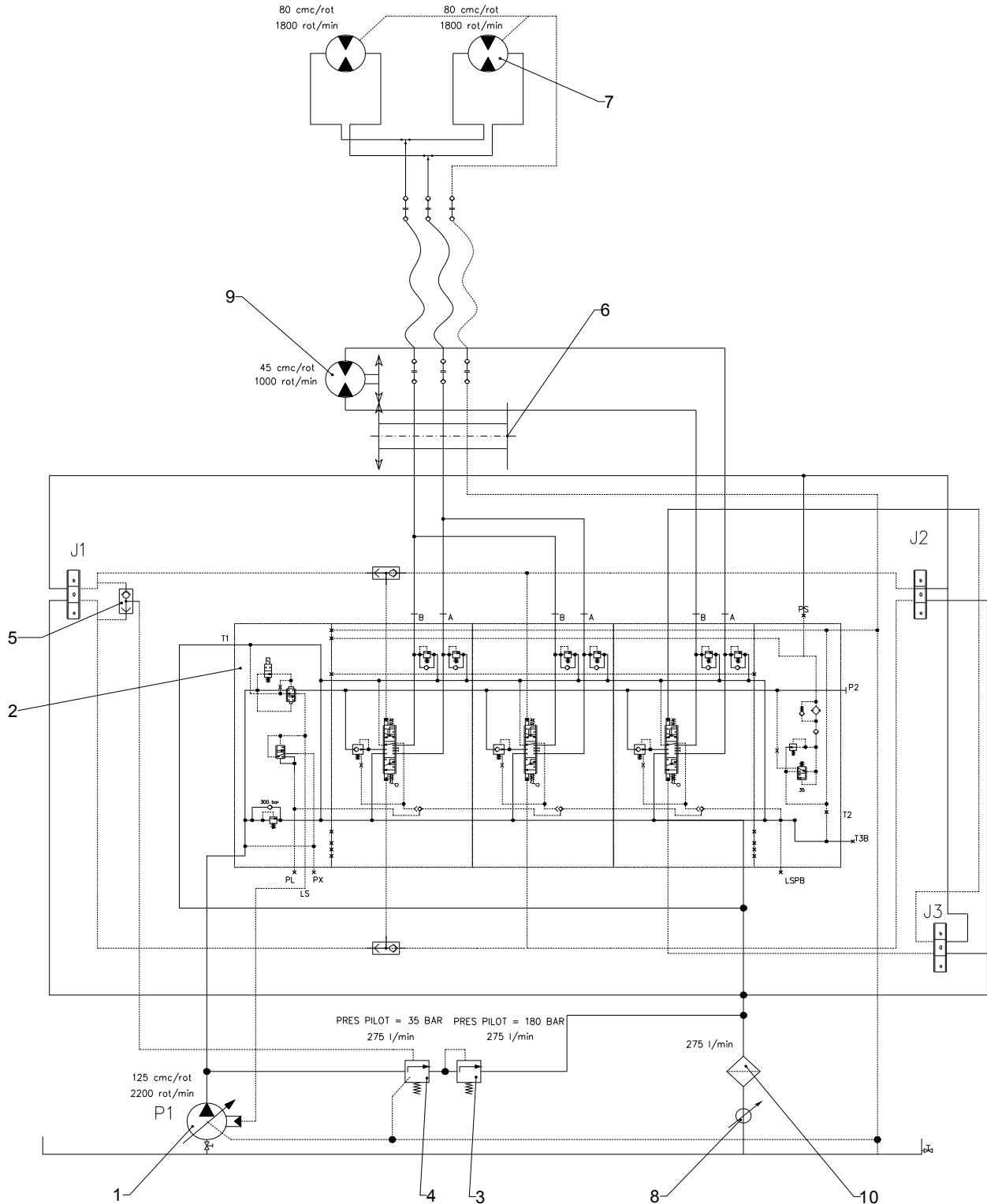



Fig. 9 Hydraulic Flow Chart

 S.C. CONFIND S.R.L. Câmpina	OPERATION MANUAL HYDRAULIC CEMENT PLUGS MILLING UNIT (HCPM) – 80 To.	Code: P4356-MU	Date: November 2012
		File: 19 / 51	Revision: 0

Hydraulic flow chart components, code: P4356-06.000

Table 6

Pos.	Description	Pcs.
1	Pump 10V O140 DRS/32L-VSD11N00E	1
2	Remote switching control 2 TH6 L06-10/M 0	3
3	Outlet filter element VSPN-12A-35	1
4	Piloted insulating valve SL20GA 1-4 X	1
5	Valve "SAU" 3/8"	3
6	Hoses drum	1
7	Hydraulic engine with axial pistons A2FM80/61W-VAB010	2
8	Digital switch mudding indicator	1
9	Drum engine GMP 50/6 10-C202.1	1
10	Return filter 7 SL 260 H10XL-S00-04D1,5-S0M00	1

Any intervention made in absence of the manufacturer's representative on the hydraulic cement plugs milling unit leads to the loss of warranty.

 S.C. CONFIND S.R.L. Câmpina	OPERATION MANUAL HYDRAULIC CEMENT PLUGS MILLING UNIT (HCPM) – 80 To.	Code: P4356-MU	Date: November 2012
		File: 20 / 51	Revision: 0

Description and operation of hydraulic scheme

Hydraulic system consists of: variable displacement flow pump and hydraulic LS (Load Sensing) regulator driven by the heat engine, three sections distributor, valves and hydraulic motors for actuation of the swivel and of the hoses drum.

Variable displacement flow pump and hydraulic LS (Load Sensing) regulator (1) is directly driven by the combustion engine at speeds between 1150 rpm and 2150 rpm, developing, when the tilt angle is maximum, flow rates ranging from 161 l / min and 301 l / min and at the swivel spindle speeds are obtained between 80 and 150 rpm.

From the pump, the hydraulic pressure is sent to the three sections distributor (2), with proportional control and hydraulic actuation and LS with a valve which is adjusted to a pressure of 290 bar (corresponding to a torque of 800kgfm for the swivel) and it is controlled with proportional remote control (joystick) J1, J2 and J3. They transmit to consumers (swivel or hose drum) the necessary energy and LS signal to the pump in order to achieve optimal consumption.

Remote J1 controls proportionally the section 1 of the distributor obtaining the following parameters of the swivel spindle: speeds between 0 rpm and 80 rpm and the maximum torque is 800 in value kg fm.

The J2 remote acts simultaneously on sections 1 and 2, in order to allow the passage of a double flow which is necessary for speeds greater than 80 rpm at the swivel spindle. Since in this case a torque of 500 kg fm is necessary, the pressure (180 bar) is limited by an external valve of the distributor (3) which requires, upstream, an insulating valve(4) actuated by the remote J2. For the isolation valve to notify the remote J2 actuation, between the two driving commands it is provided a valve "SAU" (5) that transmits the piloting pressure to the isolation valve. On the control route there are mounted two valves "SAU" to isolate J1 and J2 remotes and to actuate on sections 1 and 2 in the same time with the actuation of the remote J2.

The torque of the swivel is displayed so that the operator should correct the operating mode.

From the distributor, the fluid is sent to the drum with rotating connector and 3 sections (6) and from this through the hydraulic hoses with 40m (4x10m) length to the swivel.

On the swivel there are mounted the axial piston engines with fixed displacement of 80cm³/rot (7) which through the gear of the swivel, act against swivel spindle.

From the distributor, in section 3, it is transmitted the required energy for the actuation of the hoses drum for rolling / unrolling of them by means of the hydraulic motor (9).

The drainage circuit collects the fluids from: the pump with variable flow, isolation valve, and distributor, hydraulic motors of the swivel and of the hydraulic motor for the actuation of the drum hoses motor and discharges them in the hydraulic reservoir.

From the distributor goes out the circuit for discharging to reservoir, on which the digital flowmeter (8) is mounted for measuring back flow from the hydraulic engines, and by means of the scaling factor it is displayed on the monitoring system in speed at the swivel spindle. Before entering into the flowmeter the fluid is filtered by the return filter fitted with the plugging indicator (with digital output) which is connected to a lamp on the monitoring system in order to warn the operator about the emergency of changing the filters in the shortest time possible.

On the reservoir there are found: the discharge valve, the filling and ventilation filter and the thermometer for measuring the temperature of the hydraulic fluid. The temperature is shown on the monitoring installation and at the overhauling of the critical value the operator is visually warned for changing the working parameters or shutting off the installation.

SC CONFIND SRL	Adresa : 105600, Câmpina, str. Progresului, nr. 2, jud. Prahova, Romania Tel/Fax : 0244333160 / 0244374719 ; E-mail : confind@confind.ro
----------------	---

 S.C. CONFIND S.R.L. Câmpina	OPERATION MANUAL HYDRAULIC CEMENT PLUGS MILLING UNIT (HCPM) – 80 To.	Code: P4356-MU	Date: November 2012
		File: 21 / 51	Revision: 0

MONITORING SYSTEM

Of the hydraulic cement plugs milling unit (HCPM)

GENERAL

The system measures and indicates:

- torque and speed of the swivel;
- oil temperature from the hydraulic reservoir;
- overhauling the oil temperature from the hydraulic reservoir for a default value;
- plugging the oil filter in the hydraulic installation;

DESCRIPTION

Automation equipment consists of the following:

- Display panel on which are mounted the 3 signs IDM-01 (spindle torque, spindle speed and oil temperature) and two signal lamps (oil temperature and filter plugging);
- Oil pressure transducer (TP);
- Temperature transducer (TT);
- Thermal resistance adaptor (AT-01H);
- Switch for oil plugging.

Signals are taken from transducers in the form of electrical signals and processed by the processing unit located on the display panel. On the panel are mounted 3 indicators and 2 signaling lamps that allow visualization of the milling installation parameters.

TECHNICAL PARAMETERS

1. Multifunctional Digital Indicator IDM-01

The main component of the automation equipment is the indicator IDM-01, producer AMA control, which is in the form of an electronic module which has the following technical characteristics:

- Power ; 18...36 Vcc;
- Analog input signal: 4...20mA;
- Transmitter power supply : min. 12Vcc;
- Pulse input signal: contact "reed" free of potential;
- Pulse output signal "open collector NPN", Max. 40Vcc, galvanic isolated for input and power;
- Limit signaling: normally open relay contact 1A/60Vcc/125Vca on resistive load;
- Display: 3 digit 20mm red;
- Display Resolution: $\pm 1^\circ \text{C}$ / $\pm 1 \text{daNm}$ / $\pm 1 \text{rpm}$;;
- Display accuracy: $\pm 1^\circ \text{C}$ / $\pm 1 \text{daNm}$ / $\pm 1 \text{rpm}$;;
- Operating temperature: -20 ... 50 ° C;
- Flow constant: 14 imp / l;

2. Pressure transducer TP

- model : A-10, producer WIKA – Germany;

SC CONFIND SRL	Adresa : 105600, Câmpina, str. Progresului, nr. 2, jud. Prahova, Romania Tel/Fax : 0244333160 / 0244374719 ; E-mail : confind@confind.ro
----------------	---

 S.C. CONFIND S.R.L. Câmpina	OPERATION MANUAL HYDRAULIC CEMENT PLUGS MILLING UNIT (HCPM) – 80 To.	Code: P4356-MU	Date: November 2012
		File: 22 / 51	Revision: 0

- domain : 0...400 bar;
- output signal : 4...20mA 2 wires connection;
- power: 8...30Vcc/max. 25mA;
- fluid working temperature : -30 ... 100 °C ;
- accuracy: 0,5% BFSL.

3. Temperature transducer TT

- model : Pt100;
- domain : -50...150 °C ;
- output signal : Pt100/W=1.385;
- offset diameter : 6mm;
- offset length : 50mm;
- cable length: 2m.
- class: B.

4. Thermal resistance adaptor AT-01H

- model : AT-01H, producer AMA control;
- output signal: Pt100/W=1.385;
- domain : -30 ... 120 °C ;
- output signal : 4...20mA, linearly with temperature in two-wire connection;
- power: 10...30Vcc/max. 25mA;
- accuracy : 0,25% of measuring range;

5. Flow transducer TD

- Constant flow: 14 impulses/liter;
- Type of impulse : “contact reed”;
- Maximum frequency pulses: 100 Hz.

Monitoring system can be connected to other peripheral display / recording.

Assembly and installation

Any intervention on the monitoring system takes out of warranty the product.

For any operation of mounting / replacement of the parts it is recommended to disconnect the power source. Automation equipment hasn't its own elements of disconnection, the indicators IDM-01 are provided only with fusible and electronic plugs that limit power consumption in case of incidents (faults, defective components, etc.).

After assembling mechanical components it proceeds to their electrical connection according to wiring diagram.

Connection of the temperature transducer (TT) and the flow sensor (TD) is performed with the conductors accompanying such products after they are passed through protection tubes COPEX type.

For other connections may be used multiple spun cased conductors of 0.5 to 0.75 mm² section, of convenient lengths and routes.

MANUFACTURER: AMA CONTROL Bucharest

SC CONFIND SRL	Adresa : 105600, Câmpina, str. Progresului, nr. 2, jud. Prahova, Romania Tel/Fax : 0244333160 / 0244374719 ; E-mail : confind@confind.ro
----------------	---



S.C. CONFIND S.R.L.
Câmpina

OPERATION MANUAL
HYDRAULIC CEMENT PLUGS
MILLING UNIT (HCPM) – 80 To.

Code:
P4356-MU

Date:
November 2012

File: 23 / 51

Revision: 0

PANOU AFISARE
(vedere fata)

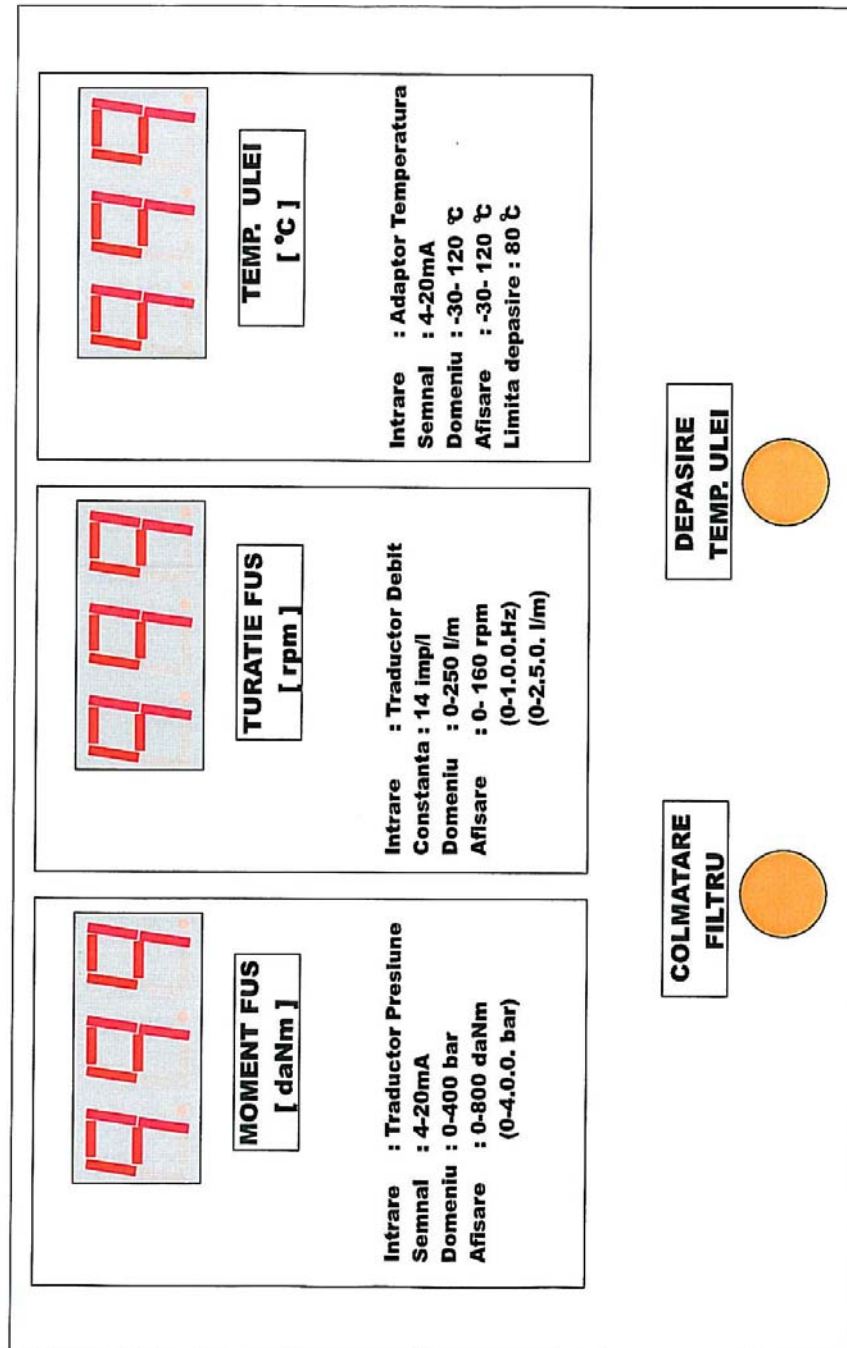

Fig. 10 Front panel monitoring system



S.C. CONFIND S.R.L.
Câmpina

OPERATION MANUAL
HYDRAULIC CEMENT PLUGS
MILLING UNIT (HCPM) – 80 To.

Code:
P4356-MU

Date:
November 2012

File: 24 / 51

Revision: 0

SCHEMA CONEXIUNI SISTEM MONITORIZARE
(vedere panou afisare din spate)

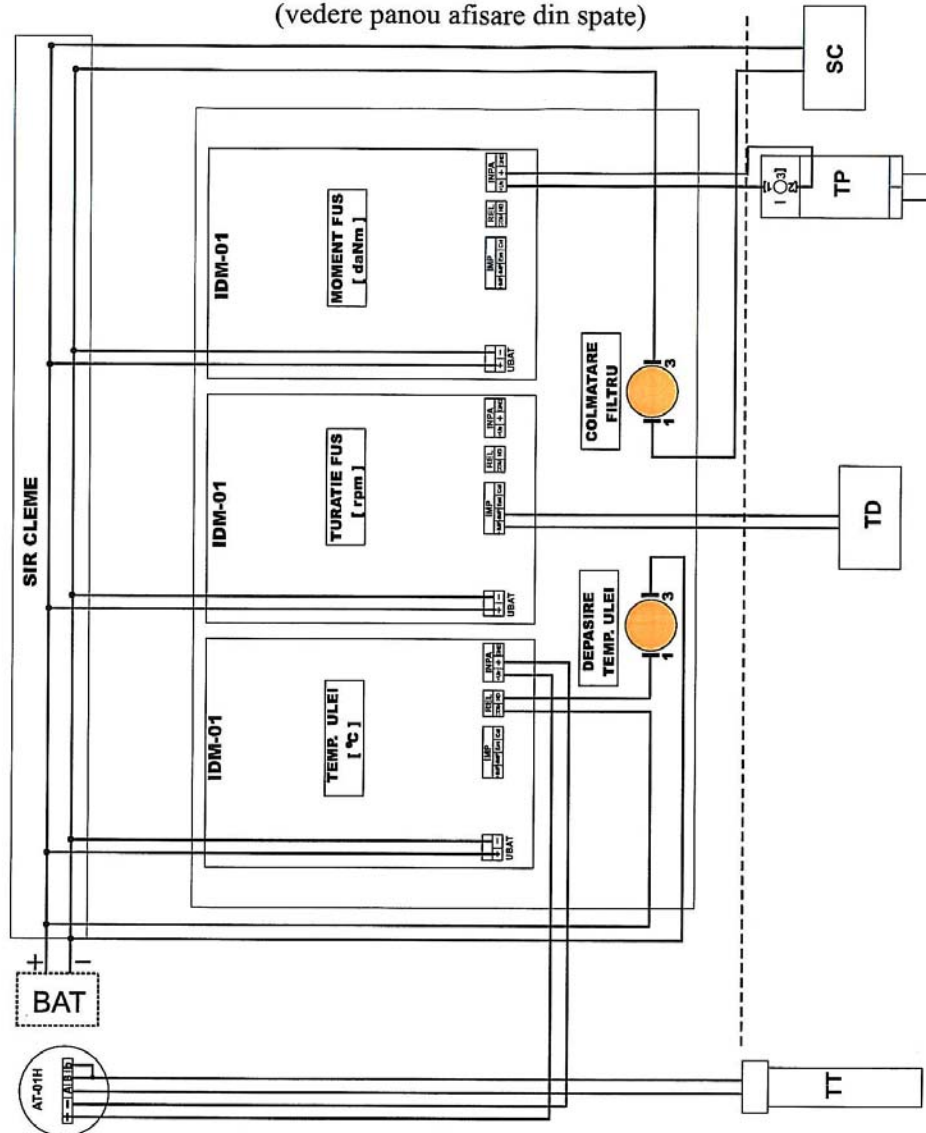

LEGENDA :

TP - Traductor Presiune
TT - Traductor Temperatura
TD - Traductor Debit
SC - Switch Colmatare
AT-01H - Adaptor termorezistenta
IDM-01 - Indicator digital multifunctional
BAT - BATERIE +24V

Fig. 11 Monitoring system wiring diagram

 S.C. CONFIND S.R.L. Câmpina	OPERATION MANUAL HYDRAULIC CEMENT PLUGS MILLING UNIT (HCPM) – 80 To.	Code: P4356-MU	Date: November 2012
		File: 25 / 51	Revision: 0

ELECTRICAL SYSTEM

TECHNICAL PARAMETERS

- Batteries.....12V, 110Ah, 2 pcs
- General switch.....100A, 24V c.c.
- Protection switch.....2A, 24V c.c.
- Plug (for connection of equipment DIGILOG).....6 pin (optionally)

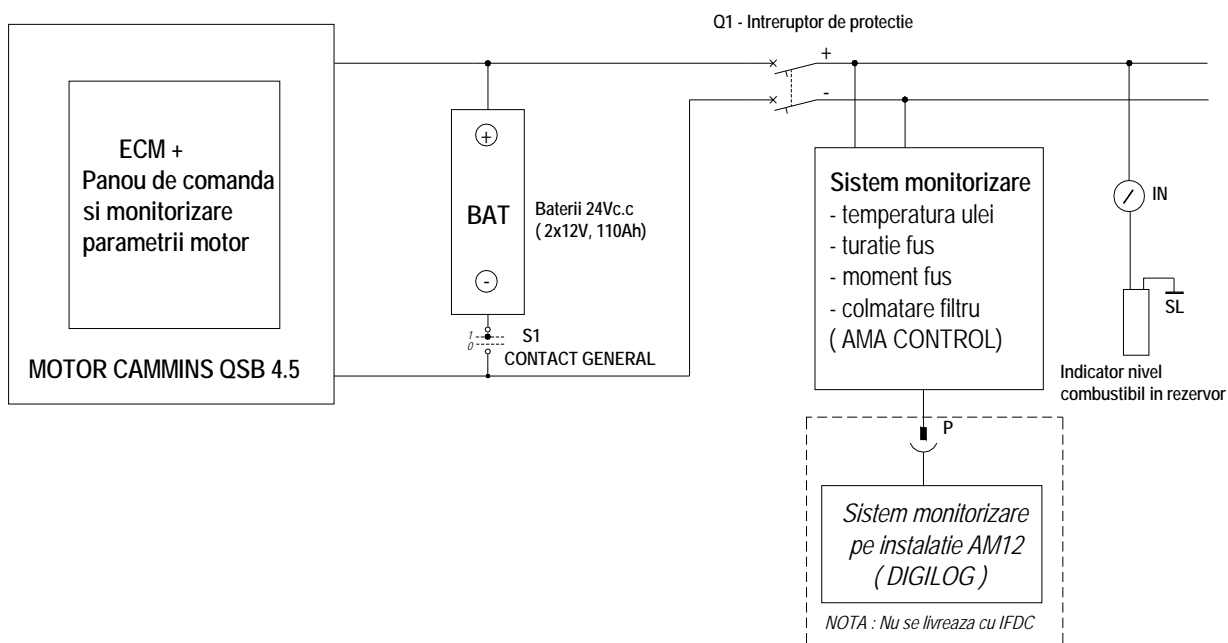

Fig. 12 Wiring Diagram



S.C. CONFIND S.R.L.
Câmpina

OPERATION MANUAL
HYDRAULIC CEMENT PLUGS
MILLING UNIT (HCPM) – 80 To.

Code:
P4356-MU

Date:
November 2012

File: 26 / 51

Revision: 0

DIESEL ENGINE: CUMMINS QSB 4.5 Tier III Stage III

Technical characteristics:

Table 7

Power	160CP/2200rpm
Torque	624Nm/1500rpm
Average diesel consumption	310 g/CP·h
Compression ratio	17,2:1
Injection system	Bosch Electronic Common Rail (pres. 1800bar)
Cylinder	4,5 l
No. of cylinders	4
Aspiration	Turbocharged and air-cooled
Oil: type / quantity	15W40 – Valvoline Premium Blue / 15 l
Antifreezing liquid: type / quantity	E.S. Complete CC275M / 20,5 l

Rating Type: Intermittent

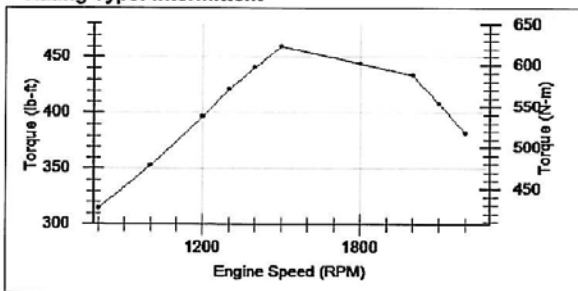

Torque Output		
RPM	lb-ft	N-m
800	314	426
1,000	353	479
1,200	397	538
1,300	421	571
1,400	441	598
1,500	460	624
1,800	444	602
2,000	433	587
2,100	408	553
2,200	382	518

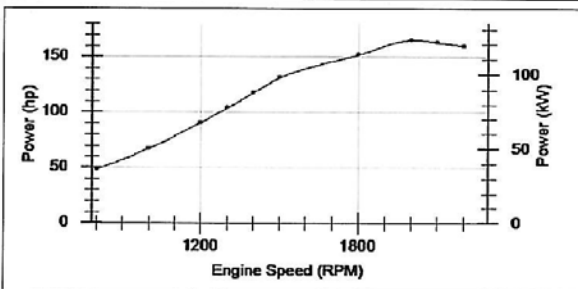

Power Output		
RPM	hp	kW
800	48	36
1,000	67	50
1,200	91	68
1,300	104	78
1,400	118	88
1,500	131	98
1,800	152	113
2,000	165	123
2,100	163	122
2,200	160	119

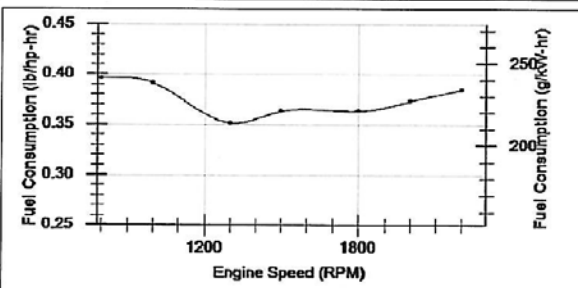

Fuel Consumption		
RPM	lb/hp-hr	g/kW-hr
800	0.396	241
1,000	0.391	238
1,300	0.352	214
1,500	0.363	221
1,800	0.363	221
2,000	0.373	227
2,200	0.385	234

Fig.13 Engine Diagrams

 S.C. CONFIND S.R.L. Câmpina	OPERATION MANUAL HYDRAULIC CEMENT PLUGS MILLING UNIT (HCPM) – 80 To.	Code: P4356-MU	Date: November 2012
		File: 27 / 51	Revision: 0

4. TRANSPORT INSTRUCTIONS, SITE INSTALLATION AND OPERATING

WARNING!



Before starting the installation and during the operation the present instructions will be studied carefully. It is imperative that these instructions and the complete technical documentation to accompany the product throughout the operating.



DO NOT TAKE YOUR MEMORY IN CONSIDERATION, THIS CAN GENERATE SEVERE ACCIDENTS.

Maintenance, exploitation and overhauling of Swivel have to be made only by skilled and trained personnel to work with this equipment.

4.1. Transport between sites.



All parts must be properly fixed and secured on the metallic frame (skid) or supports.



The swivel (HS) must be secured at the top by rotating the nuts on the special screws positioned above the guidance system arms and at the lower part it is fixed and secured the bracelet over the swivel axle.



The tanks caps and lids and the ones from engine must be properly secured to prevent leakage of oil or fuel.

Transport can be made by truck, taking into account the unit overall sizes:

- length.....5460 mm;
- width.....2000 mm;
- height.....1990 mm.



The skid will be anchored on the truck or trailer's platform.

4.2. Installation of the Hydraulic cement plugs milling unit (HCPM)



The HCPM unit location will be arranged. It must be a horizontal concrete platform (slabs) to ensure stability and a minimum contact pressure 1.5 kg/cm². The platform should not have an inclination of more than 2 degrees and the operation should not record vibrations.



The unit will be located at least 15m from the well axis. During installation, the Steel structure will be connected to a properly sized neutral belt.

 S.C. CONFIND S.R.L. Câmpina	OPERATION MANUAL HYDRAULIC CEMENT PLUGS MILLING UNIT (HCPM) – 80 To.	Code: P4356-MU	Date: November 2012
		File: 28 / 51	Revision: 0



Warning! The HCPM unit location will be made in such a manner that will allow the operator to permanently see the swivel in operation and the driller.



Lifting of the HCPM unit whose load capacity is of minimum 7 tf at a radius of 5 m and tilting angle as larger as possible, by using the special lifting system provided. The skid table is of aprox. 5t.

4.3. Ground based preparation for startup



The additional stand will be dismantled from the skid and taken close to the work platform. The operating has to be made by crane.



The anti-rotation skid elements are installed on the workover rig AM12/50 (AM12/40) as per the attached manual.

If using the HCPM unit on another type of workover rig, the anchors Ø22 are in charge of the beneficiary and these have to be vertical, parallel with the well axis, having same distance to the well axis and work in both rotation directions of the swivel spindle. Using a single anchor is not acceptable.

For the swivel on the skid the bottom bracket is loosen and the nuts securing the top are loosen. Special bolt screws will be adjustable on the back of support.

The swivel is fixed by the bails on the crane or by the guiding system arms and fixed on the additional rack.

Remove each roller from the guiding system arms (from the mast).



Check the following:

- thread condition of the swivel neck;
- thread condition of the sub 3 ½ in IF;
- slight rotation of the swivel bail in both directions;
- nuts and screws fastened on the swivel;
- easy handling of the kelly valve handling plug
- type of the Kelly valve used (left / right)



Warning! Kelly valve plug must be on open position.



After the operation, the key will be removed by the operator



The swivel fixed into the travelling block of the rig through the elevator links is positioned with the rollers on the wire ropes. The swivel bails are secured by the screw, nut, washer and splint. The rollers are installed and the travelling block lift with the swivel.

SC CONFIND SRL	Adresa : 105600, Câmpina, str. Progresului, nr. 2, jud. Prahova, Romania Tel/Fax : 0244333160 / 0244374719 ; E-mail : confind@confind.ro
----------------	---

 S.C. CONFIND S.R.L. Câmpina	OPERATION MANUAL HYDRAULIC CEMENT PLUGS MILLING UNIT (HCPM) – 80 To.	Code: P4356-MU	Date: November 2012
		File: 29 / 51	Revision: 0

Guidance system arms are firmly attached to swivel bails allowing the swivel rotation at 90° without being necessary to remove the rollers on the wire rope. Swivel handling is made by the auxiliary winch.



The additional rack is stored outside the work area.



Swivel layout on the work platform is proceeded with its side provided with side guards for the hydraulic engines. In this position the swivel is not crawling and not transported, the other guard being meant for hydraulic equipment protection.

4.4. Putting into operation



Fix the general contact to the battery.
Open the valve on the hydraulic pump suction.



Swivel (HS) controls are performed from the driller's console.
Controls for the diesel engine are performed from the engine panel located on the driller's console.

Startup of the diesel engine:

- Insert the key in contact. (pos.1);
- Speed button must be in IDLE position;
- Turn the contact key to the right in ON position and wait until the light green goes off
- Wait To Start and light yellow-Check Engine.
- Start the engine by rotating the key to START position. Do not exceed 15s. See section 5.3.
- Check the indicators condition. If the light-WATER IN FUEL is on, stop immediately (see Cummins manual)
- Leave off in idle position (relanti). Button is on IDLE position. See section 5.3.
- If the engine stops, light turns red -STOP ENGINE.
- Diesel engine parameters are shown on the display.



S.C. CONFIND S.R.L.
Câmpina

OPERATION MANUAL
HYDRAULIC CEMENT PLUGS
MILLING UNIT (HCPM) – 80 To.

Code:
P4356-MU

Date:
November 2012

File: 30 / 51

Revision: 0



Fig.14

1



Start the engine and wait until it exceeds the minimum operating temperature of hydraulic oil, which is of minimum -10°C (displayed on the control panel). The supply and drainage hoses are unfolded. To operate the supply hoses, it is necessary to act downward smoothly (hoses operation must not be sudden) the distributor lever (pos.2) from the right side of the console in terms of power carrying hoses. The distributor lever must be operated as long as the hoses are unfolded, the lever automatically returning to neutral position. There are necessary at least 2 operators for the hoses winding. A worker will serve the control console and the other one will handle the hoses. For winding the hoses, lever will be actuated. If necessary, increase the motor speed from the potentiometer on the control panel (pos.3). Engine speed is of 750rpm. Connect supply hose and drain the swivel by hammer union (FASTER).



Protective plugs are stored in the box.

The rotary hose is connected to the swivel neck.

 S.C. CONFIND S.R.L. Câmpina	OPERATION MANUAL HYDRAULIC CEMENT PLUGS MILLING UNIT (HCPM) – 80 To.	Code: P4356-MU	Date: November 2012
		File: 31 / 51	Revision: 0



Fig.15

4.5. HCPM Operation



The whole assembly will be lift by the travelling block to the upward position. Hoses shall be positioned so as not to interfere with other equipment. Follow the running on cables of the swivel.

Depending on the resisting torque, the swivel rotates around the spindle axis. is limited by cables. Arrow will not overcome 500mm.

Avoid use of the swivel and the cables loading in shocks.

Before the starting it is necessary to check the idle rotation of the swivel.

Operations are performed according to the working schedule correlated with the HCPM unit and the rig characteristics.



Handling of the swivel is made by the means of hydraulic winch.

During the operation of the swivel, the personnel access on the work platform is strictly forbidden.

SC CONFIND SRL	Adresa : 105600, Câmpina, str. Progresului, nr. 2, jud. Prahova, Romania Tel/Fax : 0244333160 / 0244374719 ; E-mail : confind@confind.ro
----------------	---

 S.C. CONFIND S.R.L. Câmpina	OPERATION MANUAL HYDRAULIC CEMENT PLUGS MILLING UNIT (HCPM) – 80 To.	Code: P4356-MU	Date: November 2012
		File: 32 / 51	Revision: 0



In case of a damage, do not longer act on the distributor's levers, they are automatically returning to the neutral position and turn the key to start the engine to the left.



Make-up the lower threaded connection of the drill pipe in the tubing coupling and fastened to the required torque.

Secure the fluid flow through the swivel.

Swivel control is operated from the hydraulic panel. There are provided on the panel two distributor's within the distributor's block (pos. 4 and 5): the one on the left side (pos. 4) controls the torque and the rotation to the left/right of the spindle, while the middle one (pos. 5) controls the speed and rotation to left/right of the swivel spindle. Levers are acted smoothly (no sudden movements). Levers are not actuated simultaneously.



Fig.16

Spindle speed adjustment is performed from the swivel hydraulic panel by rotating the potentiometer (pos. 6) and act the lever (pos.4 or pos.5). By clicking the potentiometer, this is reset and brought to the idle speed.

The engine speed is adjusted by operating the lever distributor (torque, speed) so that this will operate normally.

SC CONFIND SRL	Adresa : 105600, Câmpina, str. Progresului, nr. 2, jud. Prahova, Romania Tel/Fax : 0244333160 / 0244374719 ; E-mail : confind@confind.ro
----------------	---

 S.C. CONFIND S.R.L. Câmpina	OPERATION MANUAL HYDRAULIC CEMENT PLUGS MILLING UNIT (HCPM) – 80 To.	Code: P4356-MU	Date: November 2012
		File: 33 / 51	Revision: 0

It is forbidden to act levers pos.4 or pos.5 when the swivel is not connected to hoses.

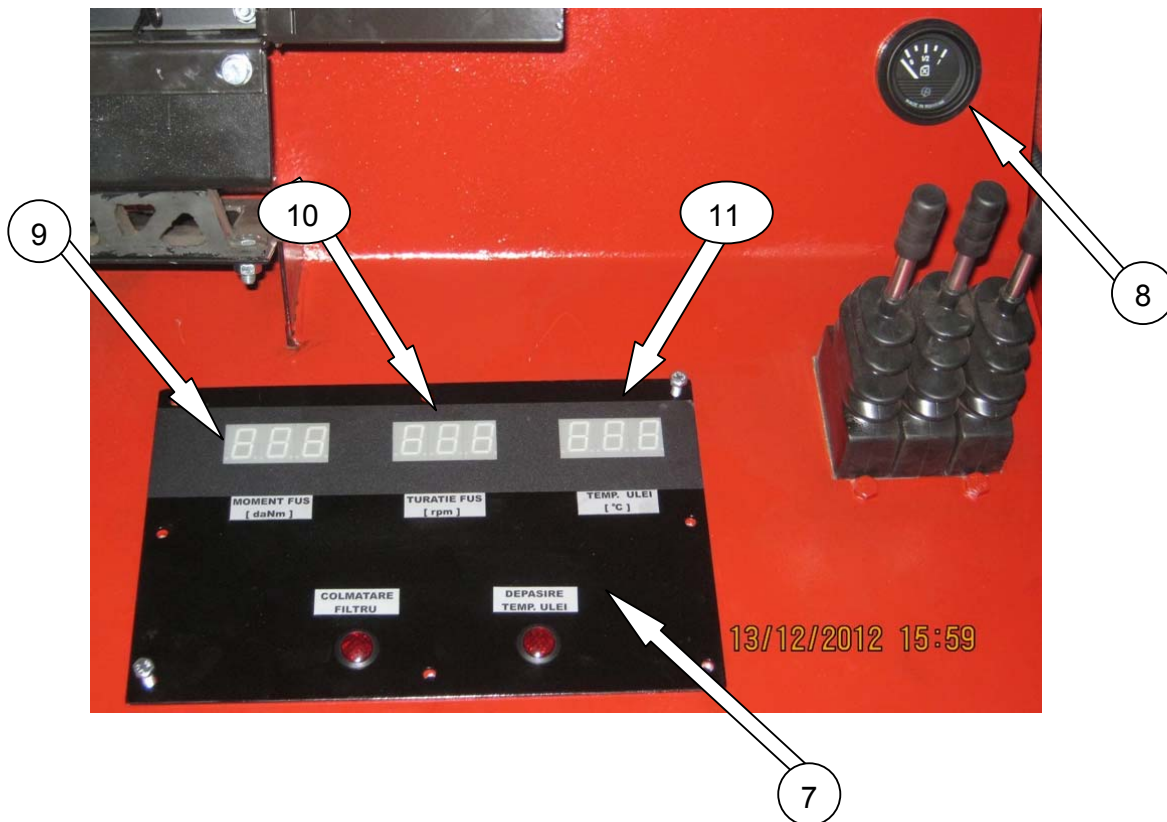

Fig.17

The monitoring system measures and indicates:

- Torque and speed of swivel;
- Oil temperature in the hydraulic tank;
- Exceeding of oil temperature in the hydraulic tank at a predefined value;
- oil filter blinding of the hydraulic unit;

On the hydraulic panel there are provided digital displays (pos.7). The left one (pos. 9) indicates the swivel torque and the one in the centre (pos. 10) indicates the swivel spindle speed. The right one (pos. 11) indicates the hydraulic oil temperature in the tank. Exceeding of the oil temperature and the hydraulic oil filter blinding is indicated by two lamps (pos. 7). When exceeding the filter blinding, the filtration element will be changed. When exceeding the hydraulic oil temperature (decrease of speed and torque, decrease pressure on the well foot).

Fuel level in the tank is displayed on the sensor (pos.8) located on the control console.

SC CONFIND SRL	Adresa : 105600, Câmpina, str. Progresului, nr. 2, jud. Prahova, Romania Tel/Fax : 0244333160 / 0244374719 ; E-mail : confind@confind.ro
----------------	---

 S.C. CONFIND S.R.L. Câmpina	OPERATION MANUAL HYDRAULIC CEMENT PLUGS MILLING UNIT (HCPM) – 80 To.	Code: P4356-MU	Date: November 2012
		File: 34 / 51	Revision: 0

Engine speed and spindle speed parameters are presented in Table 8.

Table 8

Turatia motorului termic (rpm)	Turatia fusului (motoare paralel) (rpm)
800	0-50
1200	0-90
1500	0-115
1700	0-125
2150	0-155

Engine speed is adjusted by operating distributor lever (torque, speed) so that this might function normally.

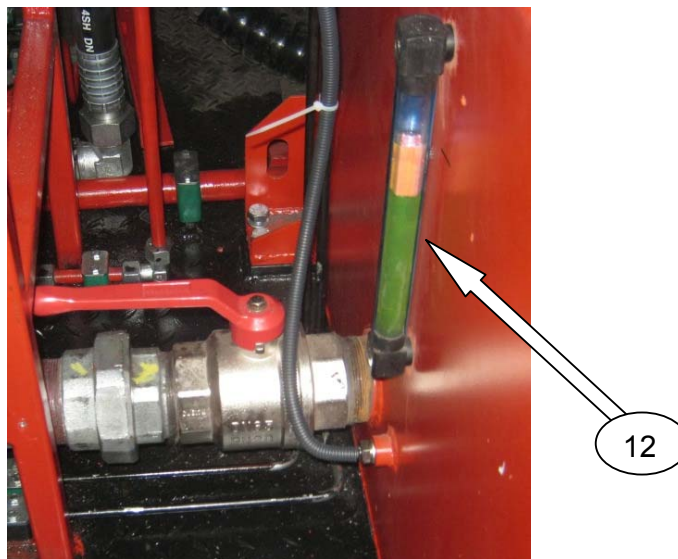

Fig.18

On the oil tank there is a sensor provided (pos. 12) for viewing the oil level.

The HCPM and engine parameters are constantly viewed on the displays located on the hydraulic panel.



Before starting of operations, it is checked the swivel idle speed.



Operations are performed according to the working schedule correlated with the HCPM unit and the rig characteristics.

 S.C. CONFIND S.R.L. Câmpina	OPERATION MANUAL HYDRAULIC CEMENT PLUGS MILLING UNIT (HCPM) – 80 To.	Code: P4356-MU	Date: November 2012
		File: 35 / 51	Revision: 0

Lower the drill string in the well and proceed operations.



Follow the hoses cinematic. Hoses must not interfere with other equipment.



In case of using on the AM12/50(AM12/40) workover rigs, it is followed the guylines arrow for taking the reactive torque. If the arrow exceeds the loading values in wire ropes of 500mm or the maximum loading, proceed with decreasing the pressure on the well foot.

When using on other rigs, the maximum loading in wire ropes and the weight in the travelling block must not exceed the load for which it was designed the derrick or the mast. In case of downgraded derricks and masts the load is the one given by the expertise made.



In case of a damage, do not longer act on the distributor's levers, they are automatically returning to the neutral position and turn the key to start the engine to the left.

The HCPM unit is equipped with guards for the operator in case they operate in bad weather conditions.



If deficiencies are noted in operation, stop immediately and fix the damage.



Will be permanently monitored the guylines fixing both in the mast and in the guiding system. It is forbidden to work only with a single guyline or by unequal tensioning. Guylines tension must be identical ($\pm 5\%$).

4.6. Preparation for moving to another location

After finishing the well operations, they are performed in reverse order to start-up and ground preparation of equipment for putting in operations.

The diesel engine stops by rotating the key inversely. The key is removed from the contact.



The dirty equipment will be cleaned.

4.7. Storage



Storage of the HCPM unit is done in sheltered places free from bad weather, so as not to enter water and mud.

SC CONFIND SRL	Adresa : 105600, Câmpina, str. Progresului, nr. 2, jud. Prahova, Romania Tel/Fax : 0244333160 / 0244374719 ; E-mail : confind@confind.ro
----------------	---

 S.C. CONFIND S.R.L. Câmpina	OPERATION MANUAL HYDRAULIC CEMENT PLUGS MILLING UNIT (HCPM) – 80 To.	Code: P4356-MU	Date: November 2012
		File: 36 / 51	Revision: 0

5. INSTRUCTIONS FOR MAINTENANCE AND REPAIR

5.1. Swivel



The gaskets from Wash pipe assembly will be inserted into the spacer rings without being lubricated, after which the remaining spaces between seals and rings will be filled with graphite grease LICA 3 or equivalent. After this operation, the rings together with gaskets will be inserted into the lower and upper Cases.



WARNING! It is forbidden to lubricate the outside of the rings and the inside of the case.



After fastening the Kelly valve on the spindle, secure it by the coupling sleeve and anti-rotation system.



Before using the Swivel, it is greased the whole Wash pipe assembly through the side-mounted grasser with lubricating pump. The operation will be repeated to max. 8 hours of operation. After raising the structural box sealing the special nut will be ensured by screw M10x55 and Grower spring spacers MN10. Do not use without safe securing.



Will be checked:

- The wash pipe run out which must be within 0,25mm and the fastening of special bolts (lower and bottom) so as to achieve a good frontal seal;
- The Swivel operation while it works (rotation and fluid circulation).
- Bearings heating;
- The wash pipe sealing.
- Oil level and if there are any oil leaks.

Table 9

Lubrication place	Quantity	Oil type	Exchange interval
Oil bath	7 l	T90EP2	500 hours or 6 months
Gear Reducer oil bath	10 l	T90EP2	500 hours or 6 months



The Swivel lubricating will be done as per the following table:

Table 10

LUBRICATION PLACE	LUBRICANT QUALITY	GUIDELINES FOR LUBRICATION
Gaskets of wash pipe	Graphite grease LICA 3 or equivalent	With lubricating pump at 8 hours
The swivel bail bolts (lubricators on body)	Grease RUL 100Ca3 or equivalent	With lubricating pump once a week
Bolts on the rollers guidance system	Graphite grease LICA 3 or equivalent	With lubricating pump at 8 hours

 S.C. CONFIND S.R.L. Câmpina	OPERATION MANUAL HYDRAULIC CEMENT PLUGS MILLING UNIT (HCPM) – 80 To.	Code: P4356-MU	Date: November 2012
		File: 37 / 51	Revision: 0

Quantity of grease : 250 g/day

Possible defects and ways to fix them:

Table 11

No.	Behavior	Causes of defect	Modes of remedy
0	1	2	3
1	Strong heating of the Swivel	Oil missing	-Filling with oil -Dismantle the Swivel, body and bearings for being cleaned and fill with oil
2	The spindle rotates slowly or it does not rotate at all	A bearing is worn or damaged	-Send to repair
3	Mud flows from the wash pipe cases	-The washing pipe is worn or damaged -The rubber gaskets are worn	-Change the washing pipe -Change gaskets
4	Mud flows from the joint connection spindle-sub	- "O" ring absent -Damaged thread	-Mounts "O" RINGS 120x5,3 -Sub is changed
5	Oil leaks between axle pin and cover	-Elastic seal with rim wear -The sleeve that friction the elastic seal is worn	-Replace the gaskets -Replace the sleeve
6	Mud inside the body in the area of bearings	-Mud infiltration in the oil-bath	-Check the gaskets at the top and replacement of worn ones, replacement of the oil
7	Swivel bail does not rotate	-Locking bolt for lack of grease	-Greasing
8	Gearbox makes noise	-Mud penetration in the bath	- Check the gaskets at the top and replacement of worn ones, replacement of the oil

5.2. Anti-Rotation device

Daily visual inspections are done to all the equipment (including welding).

Moving surfaces must be treated with grease daily.

Wire ropes will be checked daily according to the manufacturer's specifications, damaged wire ropes are not acceptable.

Damaged parts will be replaced.

Load indicators on the wire ropes must be permanently functional.

SC CONFIND SRL	Adresa : 105600, Câmpina, str. Progresului, nr. 2, jud. Prahova, Romania Tel/Fax : 0244333160 / 0244374719 ; E-mail : confind@confind.ro
----------------	---

 S.C. CONFIND S.R.L. Câmpina	OPERATION MANUAL HYDRAULIC CEMENT PLUGS MILLING UNIT (HCPM) – 80 To.	Code: P4356-MU	Date: November 2012
		File: 38 / 51	Revision: 0

5.3. Cummins Engine



Maintenance is performed according to the manufacturer's manual.

Maintenance personnel will be trained in terms of operation, functioning and maintenance of the hydraulic cement plugs milling unit.

Overhaul intervals should not be exceeded at the time of revision.

The skid (containing the Cummins engine) must be placed on a concrete platform that provides stability, vibration-free operation and may not be inclined more than **2 degrees**.

Appropriate fuel is used (without impurities, without water).

The duration of action of the key to start the engine (starter) is of maximum 15s. Three successive starts of 15s with 20s breaks are acceptable.

Switching can be resumed after a break of 1 min but before starting it is necessary check the error code.

Misuse of the contact key (breaking contact, wear) takes it out of warranty.

In case of exceeding the engine operating parameters (coolant, oil), the electronic control unit displays the overcome, it does not stop the engine operation, but the parameters are registered and may result in removal the engine of warranty if no action is taken to bring in the optimum operating parameters of the engine (reducing torque, low speed of swivel spindle).

Filters, when necessary, are changed before the period provided when used in heavy operating conditions (dust, low temperature <-20 ° C).

Red color at plugging of the air filter means that the filter has to be changed. The sensor is not reset.

Engine operating temperature is at least 40 ° C (coolant temperature).

Do not use spray on the suction manifold (for cold season start) because the engine is equipped with heating system of the air suctioned, thus existing the risk of explosion.

When necessary, clean radiator from the mud and dust deposits as it leads to engine overheating.

Warranty does not cover misuse or incorrect use (broken key in contact, terminal melted due to high starting time, broken pinion due to long driving time or the starter driving during operation, non-observance of the maintenance and operation instructions and specifications inconsistent use of consumables, use non-compliant fuel, etc.).

Referring to engine operation, this must be able to start at -29 ° C. Below this temperature the engine warms. Do not use open flame.

Table 12

Legend:	V	- visual / check / inspection / remediation
	R	- adjustment
	C	- cleaning
	I	- replacement
	RK	- capital repair – when necessary



 S.C. CONFIND S.R.L. Câmpina	OPERATION MANUAL HYDRAULIC CEMENT PLUGS MILLING UNIT (HCPM) – 80 To.	Code: P4356-MU	Date: November 2012
		File: 39 / 51	Revision: 0

Table 13

Operation	Daily made by the user	Hours of operation or period Made by CONFIND, at the date of performance must not exceed the no. of hrs. or period					Notes
		250 or 3 mths.	500 or 6 mths.	1000 or 1 year	2000 or 2 years	5000 or 4 years	
Oil level control (leakage, fill-out)	V						See Operation Manual Cummins Engine
Oil change			I				
Oil filter cartridge			I				
Diesel filter cartridge			I				
Absorbed air filter	V	V	I				
Air tube	V	V					
Air cooling pipes and radiator	V	V					
Ventilation tube for crankcase and filter	V		C+I				
Terminal battery	V	V	C				
Downloading of images in computer			V				
Adjustment of rocker arms					R	V	
V-belts (pull-up or changed when necessary)	V	V		I			
Engine leakages (losses, visual inspection) and remediation	V						
Engine supports (buffers, they are changed if worn-out)	V				V		
Check diesel pipes / collar plates fastening (losses)	V				V		
Vent	V	V		R			
Damper					V		
Radiator (losses, outward cleaning)	V	V		C			
Coolant (losses)	V	V	R		I		
Radiator stopper			V				
Radiator hoses	V	V					
Abnormal noise	V						
Injection system				V			
Drainage water-fuel separator	V		I				
Diesel tank (drainage, cleaning)				C			
Oil physical-chemical analysis						V	
Turbineblower					V		
Capital Repair		RK at 28000 hours depending on oil and diesel consumption					

 S.C. CONFIND S.R.L. Câmpina	OPERATION MANUAL HYDRAULIC CEMENT PLUGS MILLING UNIT (HCPM) – 80 To.	Code: P4356-MU	Date: November 2012
		File: 40 / 51	Revision: 0

5.4. Pumps and hydraulic engines



Maintenance is performed according to the manufacturer's datasheets (catalogs).

5.5. Hydraulic Unit



Hydraulic oil temperature during operation must not exceed 80 ° C. Indicator lamps for exceeding temperature and filter plugging are placed on the display of the hydraulic panel. In case of plugging (the lamp lights) the filter elements are replaced.



The hydraulic cement plugs milling unit maintenance will be performed as per the table below:

Table 14

Operation	Notes	Indications
Check of oil leakages	Visual	daily
Checking the oil level in the tank	Visual	daily
Checking the hydraulic hoses condition	Visual	weekly
Check of general condition	Visual If damage or signs of wear are noticed, the parts will be replaced	monthly
Checking the oil condensate	In the oil filter the water deposits are seen	monthly (winter)

Table 15

	Quantity	Type	Change interval (or filter)
Oil tank	350 l (700l)	H46A	1000 hours or 12 months

The first change is made to 250 hours of operation. If the installation did not work, the change will be made observing the interval, following which on fulfillment of the 250 hours change should be performed.

The troubleshooting of the hydraulic unit is made by CONFIND only. Unauthorized intervention takes the unit out of warranty.

SC CONFIND SRL	Adresa : 105600, Câmpina, str. Progresului, nr. 2, jud. Prahova, Romania Tel/Fax : 0244333160 / 0244374719 ; E-mail : confind@confind.ro
----------------	---

 S.C. CONFIND S.R.L. Câmpina	OPERATION MANUAL HYDRAULIC CEMENT PLUGS MILLING UNIT (HCPM) – 80 To.	Code: P4356-MU	Date: November 2012
		File: 41 / 51	Revision: 0

6. SPARE PARTS LIST

Table 16

Pos.	Description	Drawing no. /STAS	Pcs.	Supplier	Item position
1	Transmission belt	-	2	Cummins	Engine
2	Belt tensioner	-	2	Cummins	Engine
3	Thermostat	-	1	Cummins	Engine
4	Alternator	-	1	Cummins	Engine
5	Starter	-	1	Cummins	Engine
6	Turbineblower	-	1	Cummins	Engine
7	Injector	-	4	Cummins	Engine
8	Electronic control mode	-	1	Cummins	Engine
9	Water pump	-	1	Cummins	Engine
10	CPL tensioner	-	1	Cummins	Engine
11	Coarse fuel filter	3973233/ CUMMINS FS19732/ FLEETGUARD/ NELSON	5	Cummins	Engine
12	Fuel fine filter	3978040/ CUMMINS FF5421/ FLEETGUARD/ NELSON	5	Cummins	Engine
13	Engine oil filter	3937736 / CUMMINS LF3970 / FLEETGUARD/ NELSON	5	Cummins	Engine
14	Primary air filter	AF25962 / FLEETGUARD	5	Cummins	Engine
15	Secondary air filter	AF25963 / FLEETGUARD	5	Cummins	Engine
16	Key contact	-	1	Cummins	Engine
17	Engine oil	-	75 l	Cummins	Engine
18	Hydraulic oil H46EP	-	700l	Supplied	Oil tank
19	Oil T90EP2	-	100 l	Supplied	Body and Gearbox Swivel
20	Lock fastener for pipe 12x1		20	Supplied	Hydr. Unit
21	Lock fastener for pipe 16x2		3	Supplied	Hydr. Unit
22	Lock fastener for pipe 2 1/2		4	Supplied	Hydr. Unit
23	Lock fastener 25x2		2	Supplied	Hydr. Unit
24	Lock fastener for pipe 38x4		15	Supplied	Hydr. Unit
25	COLL CA-12A-2N-G10C1009215		1	Bosch-Rexroth	Hydr. Unit
26	Union cover WING STYLE 1 1/4" female		2	Hidroservice	Hydr. Unit
27	Union cover WING STYLE 1 1/4" male		2	Hidroservice	Hydr. Unit
28	Compensator AB 22-33/065NM		1	Bosch-Rexroth	Hydr. Unit
29	Galvanized iron elbow 90 FI-FI for pipe coupling at 90 grd 2 1/2"		3	Supplied	Hydr. Unit
30	Union ISO A female Dn10 3/8		1	Hidroservice	Hydr. Unit
31	Union ISO A male Dn10 3/8" HIDROSERVICE		1	Hidroservice	Hydr. Unit
32	WING Unions male+female 1 1/4		2	Hidroservice	Hydr. Unit
33	Distributor LS 3M4-15-2X		1	Bosch-Rexroth	Hydr. Unit
34	Plug 1/2 in Zn		1	Supplied	Hydr. Unit
35	Return filter 7 SL 260 H10XL-S00-04D1,5-S0M00		1	Bosch-Rexroth	Hydr. Unit

SC CONFIND SRL	Adresa : 105600, Câmpina, str. Progresului, nr. 2, jud. Prahova, Romania Tel/Fax : 0244333160 / 0244374719 ; E-mail : confind@confind.ro
----------------	---



S.C. CONFIND S.R.L.
Câmpina

OPERATION MANUAL
HYDRAULIC CEMENT PLUGS
MILLING UNIT (HCPM) – 80 To.

Code:
P4356-MU

Date:
November 2012

File: 42 / 51

Revision: 0

36	Filling and ventilation filter FEF 1 H6XL-F00		1	Bosch-Rexroth	Hydr. Unit
37	Flange A315STST/ST A3C		1	Bosch-Rexroth	Hydr. Unit
38	Flange SAE 2 1/2 A016ST		1	Bosch-Rexroth	Hydr. Unit
39	Flange SAE 2 1/2 G016ST		2	Bosch-Rexroth	Hydr. Unit
40	Flange SAE1 H30S-A400ST/STA3C		4	Bosch-Rexroth	Hydr. Unit
41	Hose 2SN DN10 DKOL M18X1.5/DKOL 90 M18X1.5 L=1200		6	Hidroservice	Hydr. Unit
42	Hose 2SN DN10 DKOL M18X1.5/DKOL 90 M18X1.5 L=1300		2	Hidroservice	Hydr. Unit
43	Hose 2SN DN10 DKOL M18X1.5/DKOL 90 M18X1.5 L=1350		2	Hidroservice	Hydr. Unit
44	Hose 2SN Dn10 DKOL90/DKOL M18x1,5 L=1500		1	Hidroservice	Hydr. Unit
45	Hose 2SN Dn10 DKOL90/DKOL M18x1,5 L=900		3	Hidroservice	Hydr. Unit
46	Hose 2SN DN12 DKOL M22X1.5/CESM22X1.5 L=10000		4	Hidroservice	Hydr. Unit
47	Hose 4SH Dn25 DKOS/SFL90 M36x2 L=400		1	Hidroservice	Hydr. Unit
48	Hose 4SH Dn25 DKOS/SFL90 M36x2 L=420		1	Hidroservice	Hydr. Unit
49	Hose 4SH Dn25 DKOS/SFL90 M36x2 L=460		1	Hidroservice	Hydr. Unit
50	Hose 4SH Dn25 DKOS/SFL90 M36x2 L=500		1	Hidroservice	Hydr. Unit
51	Hose 4SH DN32 DKOS M52X2/CES M52X2 L=10000		8	Hidroservice	Hydr. Unit
52	Hose 4SH DN32 DKOS M52x2/DKOS 90 M52X2 L=1200		2	Hidroservice	Hydr. Unit
53	Hose 4SH Dn32 DKOS/DKOS90 M52x2 L=550		1	Hidroservice	Hydr. Unit
54	Axial piston hydraulic engine A2FM80/61W-VAB010		2	Bosch-Rexroth	Hydr. Unit
55	Engine drum GMP 50/6 10-C202.1		1	Bosch-Rexroth	Hydr. Unit
56	Pump 10V O140 DRS/32L-VSD11N00E		1	Bosch-Rexroth	Hydr. Unit
57	Polyethylene spiral hose protection Ø 66		1	Hidroservice	Hydr. Unit
58	PASS VALVE OF CHROME PLATED BRASS WITH BALL AND LEVER FOR WATER FI-FI 2 1/2"		1	Supplied	Hydr. Unit
59	Flange SAE 1" hose connection 7000psi		4	Hidroservice	Hydr. Unit
60	Cartridge valve VSPN-12A-35		1	Bosch-Rexroth	Hydr. Unit
61	Isolation valve piloted SL20GA 1-4 X		1	Bosch-Rexroth	Hydr. Unit
62	Remote control unit 2 TH6 L06-		3	Bosch-	Hydr. Unit

SC CONFIND SRL

Adresa : 105600, Câmpina, str. Progresului, nr. 2, jud. Prahova, Romania
Tel/Fax : 0244333160 / 0244374719 ; E-mail : confind@confind.ro

 S.C. CONFIND S.R.L. Câmpina	OPERATION MANUAL HYDRAULIC CEMENT PLUGS MILLING UNIT (HCPM) – 80 To.	Code: P4356-MU	Date: November 2012
		File: 43 / 51	Revision: 0

	10/M 0			Rexroth	
63	Rotating seal R10F-70x54x8		6	Supplied	Drum hoses
64	O-Ring 133,4x3,5		2	Supplied	Drum hoses
65	O-ring IO 77x8.4	STAS 7320-2/80	2	Supplied	Wash pipe sealing
66	Seal oil A155x180x15	STAS 7950/1-80	3	Supplied	At the upper side of spindle
67	Seal oil A160x190x15	STAS 7950/2-87	2	Supplied	At the lower side of swivel
68	O-ring 35516000	SR ISO 3601-1:2000	1	Supplied	At the upper side of spindle
69	Gasket CH80	P3591-04.10.04	5	CONFIND	Wash pipe sealing
70	Swivel neck ass. 2x350	P3591-04.11.00	1	CONFIND	At the upper side of swivel

7. WARRANTY

The manufacturer guarantees proper operation of the hydraulic cement plugs milling unit (HCPM) for 24 months from the date of final reception with the observance of the operating instructions included in the documentation that accompanied the equipment.

The product warranty will cease if it is found that:

- Beneficiary operated the equipment inappropriately (load, fluid pressure, temperature), were not observed the operating conditions specified in this manual;
- Beneficiary uses inappropriate lubricators;
- Beneficiary tried to remove certain elements used to determine the actual causes of failure;
- Beneficiary has not taken actions for proper storage and preservation of equipment, neither before, nor after the installation of the hydraulic cement plugs milling unit.

The manufacturer has not the responsibility for the damages incurred during transportation, storage, preservation or mounting performed improperly.

The manufacturer does not change free of charge in warranty the parts which, by their nature, are wear parts or present a normal wear and are contained in the spare parts list.

For any complaint within the warranty period, it is compulsory that the removal of the CHM80 in view of the finding must be made in the presence of the manufacturer.

For any complaint within the warranty period or demand for revision shall specify also the identification data:

- skid serial number;
- swivel serial number
- engine serial number
- Petrom identification

Revisions will be made at the intervals set.

SC CONFIND SRL	Adresa : 105600, Câmpina, str. Progresului, nr. 2, jud. Prahova, Romania Tel/Fax : 0244333160 / 0244374719 ; E-mail : confind@confind.ro
----------------	---

 S.C. CONFIND S.R.L. Câmpina	OPERATION MANUAL HYDRAULIC CEMENT PLUGS MILLING UNIT (HCPM) – 80 To.	Code: P4356-MU	Date: November 2012
		File: 44 / 51	Revision: 0

8. WORK SAFETY

In accordance with Chapter 1 art. 3 Of the Work Protection Law No. 319/2006, application of the work safety rules is mandatory for all employees when carrying out their activities.

For activities that are not covered by work protection law will apply the rules of protection developed by the Ministry of Work and Social Protection.

Employees respond to any action that would remove from the operation or damage the protection devices.

If the company finds that in the engineering stage were not considered the solutions in accordance with the work safety rules, will inform the designer that is required to introduce these ones in the project.

For the operation of the hydraulic cement plugs milling unit it is necessary that the operation staff be in prior trained in terms of technical aspects and on the technical rules of security. The installation, operation and maintenance of the hydraulic cement plugs milling unit will be taken into consideration the work protection standards in the construction sites. It is forbidden to startup the unit if the moving parts are not secured by guards.

Specific work protection guidelines for each oil well will be drawn up taking into consideration these prescriptions and the norms of work protection on the handling of sub-assemblies and tools.

To ensure the proper functioning of the HCPM unit component subassemblies, the operation is made only by qualified and trained personnel in this.

In order to remove the causes that can provide accidents, before starting work, the operator will check if tools are in good conditions and they can be used in normal conditions.

In addition, to precede the work in security conditions, the operator is obliged on the followings:

- To bring to the notice of the workplace leader any faults detected;
- Comply with the technology instructions and safety at the workplace;
- To use personal protective equipment appropriate activity;
- Maintain cleanliness in the workplace.

It is prohibited to operate the HCPM unit with seals allowing fluid leakages.

Any intervention on the hydraulic system is forbidden as long as it is a pressure liquid in it.

It is forbidden to use in the hydraulic circuit the passing nuts and screws having worn thread connections. The joint of all the elements of hydraulic system must be entirely sealed.

For the prevention of accidents caused by accidental pressure fluid leaks, the worker will wear protective glasses.

When handling heavy parts it is necessary to wear protective gloves and boots with metal toecap protection.

The work place have to be organized because the disorder, narrow spaces can prevent the workers movement and materials transport, thus increasing the risk of accidents.

The hoisting equipment must be ISCIR authorized and binding parts and fixing devices must be homologated.

At the end of the work, the cables, steel ropes and lifting straps used will be disposed so

SC CONFIND SRL	Adresa : 105600, Câmpina, str. Progresului, nr. 2, jud. Prahova, Romania
	Tel/Fax : 0244333160 / 0244374719 ; E-mail : confind@confind.ro

 S.C. CONFIND S.R.L. Câmpina	OPERATION MANUAL HYDRAULIC CEMENT PLUGS MILLING UNIT (HCPM) – 80 To.	Code: P4356-MU	Date: November 2012
		File: 45 / 51	Revision: 0

that there is certainty that they will not be damaged.

Operation of lifting equipment shall be made in accordance with the provisions of the technical prescriptions.

The operator must be trained in the use of interventions means in the event of a fire and in terms of compliance with the PSI in the workplace.

In the designing and manufacturing of the HCPM unit were observed the specific occupational safety rules and technical measures. The following reference documents were used:

- Occupational health and safety Law no. 319/2006;
- Methodological Norms for applying occupational health and safety Law no. 319/2006;
- Government Decision no. 1091 of 16.08/2006 on the minimum safety and health requirements for the workplace ;
- Government Decision no. 1051/9.08.2006 on the minimum health and safety requirements for the manual handling of loads where there is a risk to workers, particularly of back injury;
- The Government decision no. 1050/09.08.2006 on the minimum requirements to ensure the safety and health of workers in the mineral-extracting and drilling industries;
- The Government decision no. 1049/09.08.2006 concerning minimum requirements to ensure the safety and health of workers in the mining and quarrying of surface or underground;
- The Government decision no. 1048/09.08.2006 concerning minimum requirements of health and safety for the use by workers of personal protective equipment at the workplace;
- The Government decision no. 971/26.07.2006 concerning minimum requirements for the provision of safety and/or health signs at work;
- The Government decision no. 300/02.03.2006 concerning minimum requirements of health and safety for temporary or mobile construction sites ;
- Government Decision no. 1876 of 22 December 2005 on the minimum health and safety requirements regarding the exposure of workers to the risks arising from vibration.
- Decision no. 752 of 05.14.2004 laying down the conditions for the placing on the market of equipment and protective systems intended for use in potentially explosive atmospheres;
- Decision no. 493 of 12/04/2006 on the minimum health and safety requirements regarding the exposure of workers to the risks arising from noise.

According to Law no. 319/2006 Safety and Health at Work, Chapter III, Section 4, Art. 13, letter e), the employer shall develop **the own instructions** for completing and / or implementation of rules of safety and health at work, taking into account the specificities of activities and jobs under their responsibility;

The personnel has the obligation to learn and follow the rules and instructions on labor protection and the implementing measures, to meet established work technology, discipline at work, use proper protective equipment and report any technical failure or other situation that constitutes a danger of injury or occupational disease. No one is allowed on installation or operating machinery with moving parts, their access is allowed only after disconnecting and insurance against accident prevention.

Putting into operation the workover equipment, maintenance or putting into production of

SC CONFIND SRL	Adresa : 105600, Câmpina, str. Progresului, nr. 2, jud. Prahova, Romania
	Tel/Fax : 0244333160 / 0244374719 ; E-mail : confind@confind.ro

 S.C. CONFIND S.R.L. Câmpina	OPERATION MANUAL HYDRAULIC CEMENT PLUGS MILLING UNIT (HCPM) – 80 To.	Code: P4356-MU	Date: November 2012
		File: 46 / 51	Revision: 0

wells, as well as the auxiliary will be made on the basis of the Reception Committee opinion that will record in the minutes that are conditions for exploiting them in complete safety. It is forbidden to start the equipment, subject to the completion of further work security measures.

Works for review, repair, adjustment, lubrication, cleaning of any parts, will be carried out after shutdown of the installation (equipment) and insurance against accidental startup.

Installation and use of traction cables will be according to technical guidelines developed for this purpose by the cable provider. Troubleshooting (roll falls, braiding, cases etc.) will be made according to guidelines developed by drilling units.

Each staff member will be trained on safety rules that must be respected throughout the work.

Hand tools will be maintained, as appropriate, in cases, racks or drawers compartmentalized and will be cleaned after each use. Tools necessary to perform work at height will be held in special bags made of resistant or-if necessary-linked individual separately. They shall not exceed a total of 10 kg. It is forbidden to climb the height wearing the tools in the hands or clothing pockets. At the work carried out at height, hand tools will be mandatory used with clamps by hand to prevent accidental fall from a height of these.

If it is determined that the noise level exceeds the allowed maximum (87 Bb) employees must wear personal protective equipment against noise (outer protection helmets).

Where the hydraulic cement plugs milling unit is not directly installed on location, actions will be taken to be kept tidy, labeled, preserved and stored so as not to impede movement.

It is forbidden to start the unit if the guards and handrails are not fixed, as per the documentation, that is:

- chains and moving parts are not protected by guards;
- platform is not provided by the handrails;

Using the headset and protective equipment is compulsory for all staff working in the area of operating unit.

Not permitted:

- Change of the assembly without the agreement of the designer;
- Commissioning of the equipment after every stop, without protective and safety devices, which they were equipped with;
- Dismantling facilities during the operation of the installations.

Machinery, equipment and other drilling equipment installations will be reviewed periodically and repaired according to prescriptions issued by the manufacturer. The protective and safety devices shall be maintained in normal operating mode of functioning.

In the event of accidents during construction or during operation, servicing / repairs, contractor and respectively the customer will be taking care of giving first aid by applying the appropriate procedures set out in the guidance "**First aid at the accident site**", edited by Ministry of Labor and Social Protection, Department of Labor Protection.

SC CONFIND SRL	Adresa : 105600, Câmpina, str. Progresului, nr. 2, jud. Prahova, Romania Tel/Fax : 0244333160 / 0244374719 ; E-mail : confind@confind.ro
----------------	---

 S.C. CONFIND S.R.L. Câmpina	OPERATION MANUAL HYDRAULIC CEMENT PLUGS MILLING UNIT (HCPM) – 80 To.	Code: P4356-MU	Date: November 2012
		File: 47 / 51	Revision: 0

9. ENVIRONMENT PROTECTION

- The well hole activity is carried out on the perimeters with diversified terms of relief, vegetation, watercourses and human areas.
- In this respect, to protect the environment, the leaders of workplaces must comply with the rules of environment protection and to take all actions required to prevent such environmental disaster.
- By its operation, the hydraulic cement plugs milling unit has not negative influence on the environment.
- Noise level values should not exceed the maximum allowed of 87 dB.
- The unit mechanisms, oil and fuel tanks, were designed so that the sealing elements may not allow leaking oil or coolant, to work securely and do not pollute the environment;
- The filling of the oil bath will be made carefully so as not to exceed the maximum level and drain on the plant or soil; if this happened, immediate actions will be taken to clean the place;
- When repairing, if it is necessary to empty the oil bath, this has to be done in special containers;
- Will check out the oil retainer rings and filling plug for possible leakages;
- All the connection pipes and hoses will be sealed and strongly fixed;
- It will make measurements of the platform surrounding air and in case of a concentration of hydrocarbon over 300mg/m³ the work must be stopped and people removed from the area.

SC CONFIND SRL	Adresa : 105600, Câmpina, str. Progresului, nr. 2, jud. Prahova, Romania Tel/Fax : 0244333160 / 0244374719 ; E-mail : confind@confind.ro
----------------	---

 S.C. CONFIND S.R.L. Câmpina	OPERATION MANUAL HYDRAULIC CEMENT PLUGS MILLING UNIT (HCPM) – 80 To.	Code: P4356-MU	Date: November 2012
		File: 48 / 51	Revision: 0

SPARE PARTS LIST FOR HCPM UNIT

Pos.	Description	Drawing no. /STAS	Pcs.	Supplier	Item position	CONFIND Code
1	Transmission belt	-	2	Cummins	Engine	
2	Belt tensioner	-	2	Cummins	Engine	
3	Thermostat	-	1	Cummins	Engine	
4	Alternator	-	1	Cummins	Engine	M1001000450102
5	Starter	-	1	Cummins	Engine	
6	Turbineblower	-	1	Cummins	Engine	
7	Injector	-	4	Cummins	Engine	
8	Electronic control mode	-	1	Cummins	Engine	
9	Water pump	-	1	Cummins	Engine	
10	CPL tensioner	-	1	Cummins	Engine	
11	Coarse fuel filter	3973233/ CUMMINS FS19732/ FLEETGUARD/ NELSON	5	Cummins	Engine	M1001000200822
12	Fuel fine filter	3978040/ CUMMINS FF5421/ FLEETGUARD/ NELSON	5	Cummins	Engine	M1001000200823
13	Engine oil filter	3937736 / CUMMINS LF3970 / FLEETGUARD/ NELSON	5	Cummins	Engine	M1001000200626
14	Primary air filter	AF25962 / FLEETGUARD	5	Cummins	Engine	M1001000300715
15	Secondary air filter	AF25963 / FLEETGUARD	5	Cummins	Engine	M1001000400715
16	Key contact	-	1	Cummins	Engine	
17	Engine oil	-	75 l	Cummins	Engine	A5401000031607
18	Hydraulic oil H46EP	-	700l	Supplied	Oil tank	A5401000010101
19	Oil T90EP2	-	100 l	Supplied	Body and Gearbox Swivel	A5401000030101
20	Lock fastener for pipe 12x1		20	Supplied	Hydr. Unit	R1101001210101
21	Lock fastener for pipe 16x2		3	Supplied	Hydr. Unit	R1101001620101
22	Lock fastener for pipe 2 ½		4	Supplied	Hydr. Unit	R1101002120101
23	Lock fastener 25x2		2	Supplied	Hydr. Unit	R1101002520101
24	Lock fastener for pipe 38x4		15	Supplied	Hydr. Unit	R1101003840101
25	COLL CA-12A-2N-G10C1009215		1	Bosch-Rexroth	Hydr. Unit	C0604100920101

SC CONFIND SRL	Adresa : 105600, Câmpina, str. Progresului, nr. 2, jud. Prahova, Romania Tel/Fax : 0244333160 / 0244374719 ; E-mail : confind@confind.ro
----------------	---



S.C. CONFIND S.R.L.
Câmpina

OPERATION MANUAL
HYDRAULIC CEMENT PLUGS
MILLING UNIT (HCPM) – 80 To.

Code:
P4356-MU

Date:
November 2012

File: 49 / 51

Revision: 0

26	Union cover WING STYLE 1 1/4" female		2	Hidroservice	Hydr. Unit	E1099001140404
27	Union cover WING STYLE 1 1/4" male		2	Hidroservice	Hydr. Unit	E1099001140405
28	Compensator AB 22- 33/065NM		1	Bosch- Rexroth	Hydr. Unit	C0730022330101
29	Galvanized iron elbow 90 FI-FI for pipe coupling at 90 grd 2 1/2"		3	Supplied	Hydr. Unit	C0701000100236
30	Union ISO A female Dn10 3/8		1	Hidroservice	Hydr. Unit	E1099000050517
31	Union ISO A male Dn10 3/8" HIDROSERVICE		1	Hidroservice	Hydr. Unit	E1099000050518
32	WING Unions male+female 1 ¼		2	Hidroservice	Hydr. Unit	E1099001140304
33	Distributor LS 3M4-15- 2X		1	Bosch- Rexroth	Hydr. Unit	M1077341520101
34	Plug 1/2 in Zn		1	Supplied	Hydr. Unit	C0710000020301
35	Return filter 7 SL 260 H10XL-S00-04D1,5- S0M00		1	Bosch- Rexroth	Hydr. Unit	C0728072600101
36	Filling and ventilation filter FEF 1 H6XL-F00		1	Bosch- Rexroth	Hydr. Unit	C0728016000101
37	Flange A315STST/ST A3C		1	Bosch- Rexroth	Hydr. Unit	C0607031530101
38	Flange SAE 2 1/2 A016ST		1	Bosch- Rexroth	Hydr. Unit	C0607000160101
39	Flange SAE 2 1/2 G016ST		2	Bosch- Rexroth	Hydr. Unit	C0607000160102
40	Flange SAE1 H30S- A400ST/STA3C		4	Bosch- Rexroth	Hydr. Unit	C0607304000101
41	Hose 2SN DN10 DKOL M18X1.5/DKOL 90 M18X1.5 L=1200		6	Hidroservice	Hydr. Unit	M1001120000101
42	Hose 2SN DN10 DKOL M18X1.5/DKOL 90 M18X1.5 L=1300		2	Hidroservice	Hydr. Unit	M1001130000101
43	Hose 2SN DN10 DKOL M18X1.5/DKOL 90 M18X1.5 L=1350		2	Hidroservice	Hydr. Unit	M1001135000101
44	Hose 2SN Dn10 DKOL90/DKOL M18x1,5 L=1500		1	Hidroservice	Hydr. Unit	M1001003500213
45	Hose 2SN Dn10 DKOL90/DKOL M18x1,5 L=900		3	Hidroservice	Hydr. Unit	M1001003500214
46	Hose 2SN DN12 DKOL M22X1.5/CESM22X1.5 L=10000		4	Hidroservice	Hydr. Unit	M1001022150101

SC CONFIND SRL

Adresa : 105600, Câmpina, str. Progresului, nr. 2, jud. Prahova, Romania
Tel/Fax : 0244333160 / 0244374719 ; E-mail : confind@confind.ro



S.C. CONFIND S.R.L.
Câmpina

OPERATION MANUAL
HYDRAULIC CEMENT PLUGS
MILLING UNIT (HCPM) – 80 To.

Code:
P4356-MU

Date:
November 2012

File: 50 / 51

Revision: 0

47	Hose 4SH Dn25 DKOS/SFL90 M36x2 L=400		1	Hidroservice	Hydr. Unit	C0732003620420
48	Hose 4SH Dn25 DKOS/SFL90 M36x2 L=420		1	Hidroservice	Hydr. Unit	C0732003620421
49	Hose 4SH Dn25 DKOS/SFL90 M36x2 L=460		1	Hidroservice	Hydr. Unit	C0732003620419
50	Hose 4SH Dn25 DKOS/SFL90 M36x2 L=500		1	Hidroservice	Hydr. Unit	C0732003620422
51	Hose 4SH DN32 DKOS M52X2/CES M52X2 L=10000		8	Hidroservice	Hydr. Unit	C0732005220101
52	Hose 4SH DN32 DKOS M52x2/DKOS 90 M52X2 L=1200		2	Hidroservice	Hydr. Unit	C0732005222117
53	Hose 4SH Dn32 DKOS/DKOS90 M52x2 L=550		1	Hidroservice	Hydr. Unit	C0732005220419
54	Axial piston hydraulic engine A2FM80/61W- VAB010		2	Bosch- Rexroth	Hydr. Unit	C0730280610101
55	Engine drum GMP 50/6 10-C202.1		1	Bosch- Rexroth	Hydr. Unit	M1001506100101
56	Pump 10V O140 DRS/32L-VSD11N00E		1	Bosch- Rexroth	Hydr. Unit	C0730101400101
57	Polyethylene spiral hose protection Ø 66		1	Hidroservice	Hydr. Unit	L5401000010706
58	PASS VALVE OF CHROME PLATED BRASS WITH BALL AND LEVER FOR WATER FI-FI 2 1/2"		1	Supplied	Hydr. Unit	C0727000690101
59	Flange SAE 1" hose connection 7000psi		4	Hidroservice	Hydr. Unit	B1390170000101
60	Cartridge valve VSPN- 12A-35		1	Bosch- Rexroth	Hydr. Unit	C0604121000101
61	Isolation valve piloted		1	Bosch- Rexroth	Hydr. Unit	C0604020140201
62	SL20GA 1-4 X	M1001266100101				
63	Remote control unit 2 TH6 L06-10/M 0		3	Bosch- Rexroth	Hydr. Unit	C0732705480101
64	Rotating seal R10F- 70x54x8		6	Supplied	Drum hoses	L4303000350101
65	O-Ring 133,4x3,5		2	Supplied	Drum hoses	L4303007810101
66	O-ring IO 77x8.4	STAS 7320-2/80	2	Supplied	Wash pipe sealing	M1001155180101
67	Seal oil A155x180x15	STAS 7950/1-80	3	Supplied	At the upper side of spindle	L4303160190101

SC CONFIND SRL

Adresa : 105600, Câmpina, str. Progresului, nr. 2, jud. Prahova, Romania

Tel/Fax : 0244333160 / 0244374719 ; E-mail : confind@confind.ro



S.C. CONFIND S.R.L.
Câmpina

OPERATION MANUAL
HYDRAULIC CEMENT PLUGS
MILLING UNIT (HCPM) – 80 To.

Code:
P4356-MU

Date:
November 2012

File: 51 / 51

Revision: 0

68	Seal oil A160x190x15	STAS 7950/2-87	2	Supplied	At the lower side of swivel	L4303000980101
69	O-ring 35516000	SR ISO 3601-1:2000	1	Supplied	At the upper side of spindle	L4308000800201
70	Gasket CH80	P3591-04.10.04	5	CONFIND	Wash pipe sealing	P3591-04.11.00