

Progressive cavity pumps

Since 2000, CONFIND manufactures pumping units with eccentric rotor and rubber stator, also known as progressive cavity pumps.

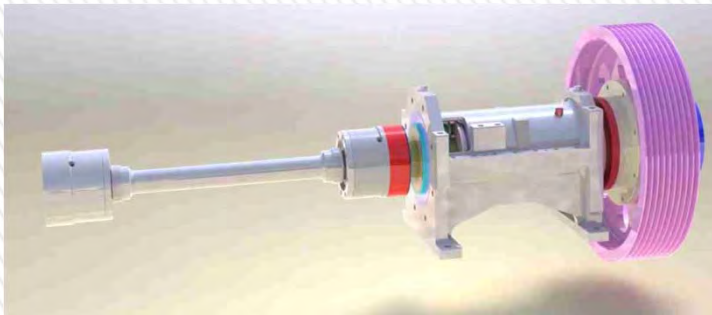

Progressive cavity pumps

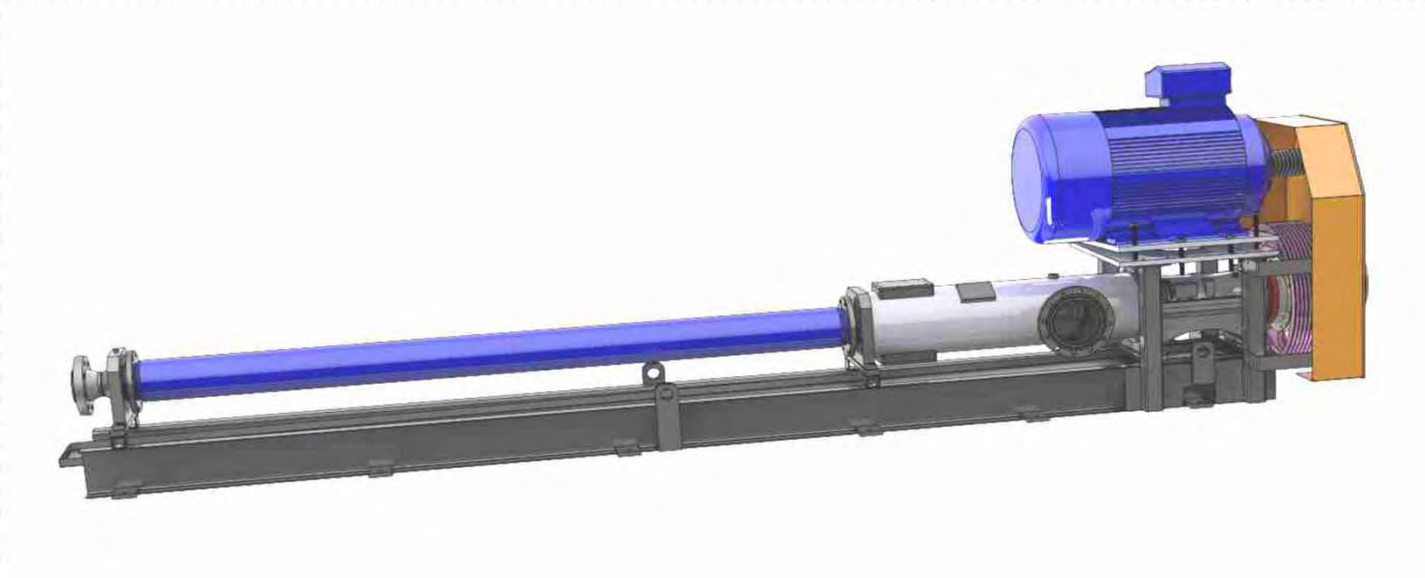
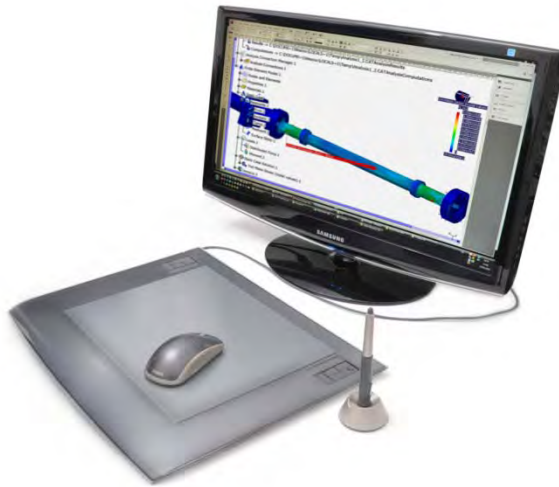

This document belongs to SC CONFIND srl and contains confidential information. Upon receipt of this document, the recipient accepts that this is a confidential document and has to be used solely for the purpose it has been received. The recipient will return this document to SC CONFIND srl upon request.

Progressive cavity pumps

At the present time
CONFIND manufactures
these types of pumps.
Starting with 2014 regular
pumps are available in
stock for quick deliveries.

CENTRALIZATOR GRUPURI DE POMPARE CU POMPE CAVITATI PROGRESIVE (PCP)						
No	Pump ID	Pump type	Fluid	Pump code	Maximum flow at maximum pressure [cm ³ /h]	Maximum pressure [bar]
1	GP10.06	horizontal	crude oil	P3147-00-T	10	6
2	GP10.06	horizontal	salt water	P3147-00-AS	10	6
3	GP10.12	horizontal	crude oil	P3184-00-T	10	12
4	GP10.12	horizontal	salt water	P3184-00-AS	10	12
5	GP10.24	horizontal	crude oil	P1555-00-T	10	24
6	GP10.24	horizontal	salt water	P1555-00-AS	10	24
7	GP10.48	horizontal	crude oil	P1876-00-T	10	48
8	GP10.48	horizontal	salt water	P1876-00-AS	10	48
9	GP15.100	horizontal	crude oil	P1556-00-T	15	100
10	GP15.100	horizontal	salt water	P1556-00-AS	15	100
11	GP20.12	horizontal	crude oil	P2678-00-T	20	12
12	GP20.12	horizontal	salt water	P2678-00-AS	20	12
13	GP20.24	horizontal	crude oil	P1554-00-T	20	24
14	GP20.24	horizontal	salt water	P1554-00-AS	20	24
15	GP20.48	horizontal	salt water	P1560-00-AS	20	48
16	GP25.80	horizontal	crude oil	P1830-00-T	25	80
17	GP25.80	horizontal	salt water	P1830-00-AS	25	80
18	GP25.120	horizontal	crude oil	P4829-00-T	25	120
19	GP25.120	horizontal	salt water	P4829-00-AS	25	120
20	GP30.50	horizontal	crude oil	P2460-00-T	30	50
21	GP30.50	horizontal	salt water	P2460-00-AS	30	50
22	GP40.12	horizontal	crude oil	P2797-00-T	40	12
23	GP40.12	horizontal	salt water	P2797-00-AS	40	12
24	GP40.24	horizontal	crude oil	P3680-00-T	40	24
25	GP40.24	horizontal	salt water	P3680-00-AS	40	24
26	GP60.12	horizontal	crude oil	P1959-00-T	60	12
27	GP60.12	horizontal	salt water	P1959-00-AS	60	12
28	GP60.24	horizontal	crude oil	P1960-00-T	60	24
29	GP60.24	horizontal	salt water	P1960-00-AS	60	24
30	GP60.36	horizontal	crude oil	P3838-00-T	60	36
31	GP60.36	horizontal	salt water	P3838-00-AS	60	36
32	GP60.48	horizontal	crude oil	P4293-00-T	60	48
33	GP60.48	horizontal	salt water	P4293-00-AS	60	48
34	PB10.06	vertical	sludge	P4680-00	10	6
35	PB10.12	vertical	sludge	P3888-00	10	12
36	PB10.24	vertical	sludge	P3782-00	10	24
37	PB20.12	vertical	sludge	P2899-00	20	12
38	PB60.12	vertical	sludge	P3729-00	60	12

Progressive cavity pumps

Categories of pumps

Pumps for crude oil and crude oil products

Pumps for salt water

Upon request we can provide pumps for other applications:

Pumps for high temperature(170 °C)

Pumps for fluids that contain H₂S si CO₂

Pumps for food industry

Pumps for corrosive and abrasive fluids

Progressive cavity pumps

In order to avoid later problems, each order must be accompanied by the procurement data sheet filled in by the Client

Procurement data sheet for progressive cavity pump operating on crude oil or salt water			
1	Client:	Pump location:	
3	Name/Surname: Phone: E-mail:	Quantity:	
5	Pump type:		
6	Horizontal pump: GP	<input type="checkbox"/> Yes	<input type="checkbox"/> No
7	Vertical pump(for drain tanks etc): PB(Nota 2)	<input type="checkbox"/> Yes	<input type="checkbox"/> No
9	Tank dimensions: depth(m) length x width (mxm) diameter of the manhole(m)		
10	Operating conditions:		
11	Operating fluid(Nota 1):	<input type="checkbox"/> crude oil	<input type="checkbox"/> salt water
13	Characteristics of fluid(Nota 3):		
14	Fluid temperature(°C):	Normal	Max Min
16	Required flow(m³/h):	Working time: h/day on	h/day off
18	Fluid gravity(kg/dm³):	Viscosity(cSt):	
20	Discharge pressure(bar):	Suction pressure(bar):	Max Min
22	Ambient temperature(°C):	Normal	Max Min
24	EX zone: Zone Temperature class	NPSH (mcolH ₂ O):	Max Min
26	Safety equipment: (liquid presence sensor on inlet, pressure sensor and pressure indicator on discharge)	<input type="checkbox"/> Yes	<input type="checkbox"/> No
27	Heat tracing (Nota 4):	<input type="checkbox"/> Yes	<input type="checkbox"/> No
28	Pump location:	<input type="checkbox"/> indoor <input type="checkbox"/> outdoor <input type="checkbox"/> heated <input type="checkbox"/> not heated <input type="checkbox"/> only cover	
29	Sealing type:	<input type="checkbox"/> soft <input type="checkbox"/> mechanical	
30	Motor: Voltage(V) Frequency(Hz)	<input type="checkbox"/> variable speed <input type="checkbox"/> constant speed	
31	Remarks:		
32			
33			

34 **Nota 1 (recommendations regarding pump type: crude oil or salt water)**

35 Suction from the crude oil compartment of the separator, oil content ≥75% → crude oil pump

36 Suction from the crude oil tank, oil content ≥75% → crude oil pump

37 Salt water injection → salt water pump

38 Salt water circulation → salt water pump

39 Cycle pumping of crude oil and salt water → salt water pump

40 Crude oil pumping, salt water in mixture ≥ 75% → salt water pump

41 Crude oil pumping, crude oil in mixture ≥ 25% → crude oil pump

42 **Nota 2**

43 Technical specifications of the vertical pumps(PB) define the requirements for the tanks in order to enable a rigid installation. In case the tanks do not fulfill these requirements, the deliverables do not include the fixtures required by the installation, that will be quoted on a case by case basis.

45 Information regarding the forces generated by the pumps as well as an installation proposal will be submitted to the Client upon request.

47 **Nota 3**

48 For a proper selection of stator it is mandatory to receive from the Client the content of H₂S, CO₂, aromatic substances, acids, free gas(if more than 5% volume at the suction pressure) as well as fluid temperature if above 80 °C. In case no such information are presented with the inquiry, we shall consider that are not applicable.

50 **Nota 4**

51 Heat tracing characteristics:
T_{maintained}=15°C; 230V

52 **Nota 5**

Pump can be fitted optionally as follows:

- 1) Safety equipment inlet(liquid sensor)
- 2) Safety equipment discharge(pressure gauge and pressure meter)
- 3) Heat tracing
- 4) Mechanical seal. Normal pump has soft seal.

These options are not included in the pump price and will be inquired for and quoted separately.

Progressive cavity pumps

For a smooth and organized execution of maintenance and repair activities the following steps should be applied:



- Based on the contract, the written request from the Client is recorded in the system;
- Service team goes to the site and performs a technical assessment of the pump, filling in the assessment form that includes the solutions to be adopted in order to reinstate the pump initial operating parameters;
- Technical assessment form is confirmed by the Client;
- Based on this form, the cost sheet is prepared, including replaced parts, repaired parts, time required by these activities and is submitted to Client for verification and approval.
- Pump is repaired either on the site or in CONFIND, depending on the extent and complexity of the repairing activity;
- Pump is tested on location and put in function – if the repairing is performed on site;
- Pump is tested on test bench in CONFIND, brought to the site and put in function – if the repairing is performed at the factory;
- The repairing activity is invoiced based on the cost sheet and the put in function protocol.

Service teams respond to any request within 48 hours on the territory of Romania.

Progressive cavity pumps

In parallel with current pump manufacturing, CONFIND performs a significant research and development activity in the following areas of interest:

Description	Advantages
Developing even wall stators.	Performance increase. Decreased length.
Developing high pressure rotors carbide coated using HVOF process	Increase pump lifetime.
Improvement of elastomer characteristics for stators	Increase pump lifetime.
Rotor coating sealing and densification	Increase pump lifetime.
Replaceable shell stators for low pressure	Increase pump lifetime. Decrease of operating costs.
Developing taper rotor-stator sets	Increase pump lifetime.
Developing multiphase pumps	Pumping fluids with high free gas content.

Progressive cavity pumps



Even wall stator having as a purpose:

- Decrease stator-rotor fit – decrease wear
- Pressure increase from 6 bar to 9 bar per pitch

Regular stator



Rotor carbide coating (high velocity oxygen fuel) having as a purpose:

- Increase of corrosion and abrasion resistance compared to hard chrome coating
- Enable repairing activity of the rotor

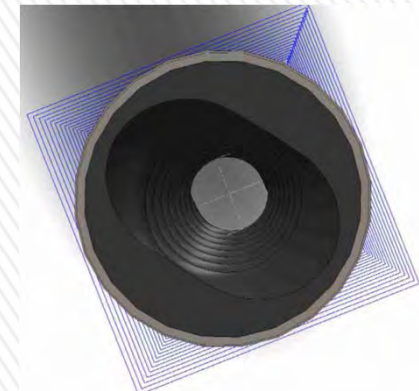
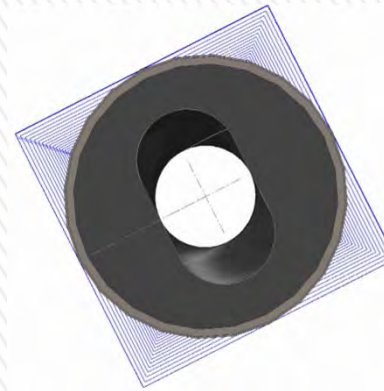
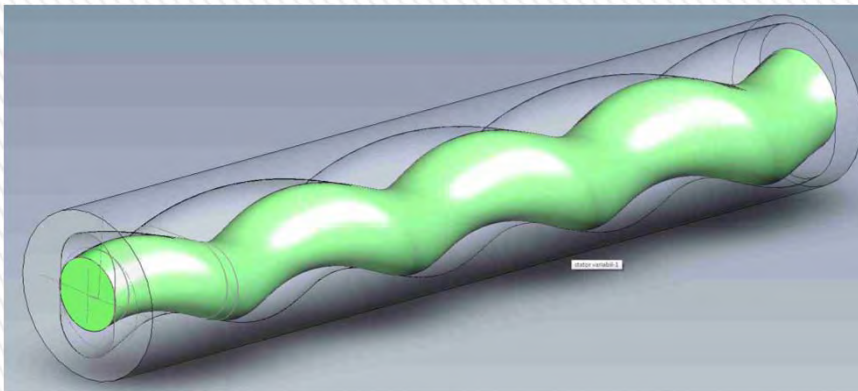

Taper type rotor-stator set having as a purpose:

- wear compensation

Progressive cavity pumps

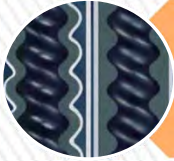

Research and development is based on the following elements

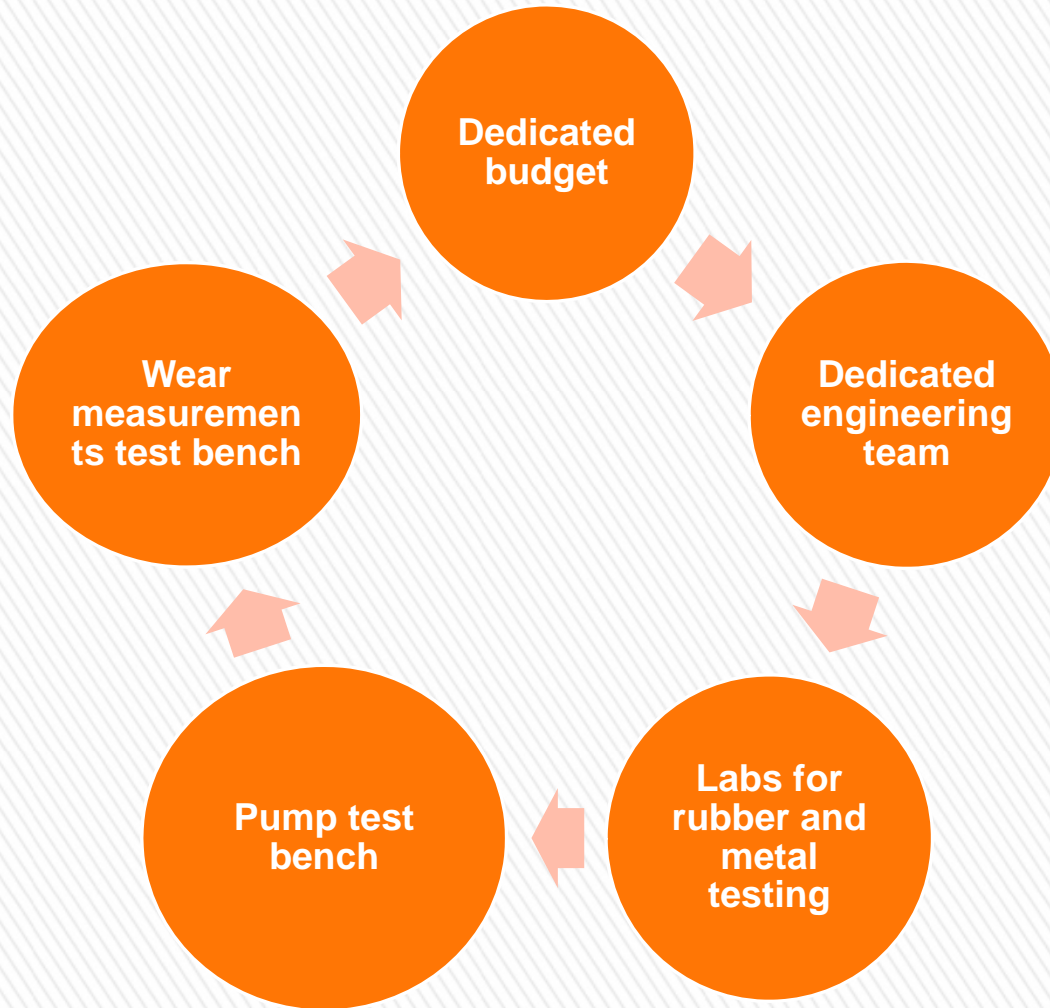

Progressive cavity pumps

An important element in the research and development activity is the pump test bench that allows liquid tests as well as liquid+air tests.

Test bench has as the purpose to create similar conditions as in reality, operates in manual and automated modes and enables the acquisition of the following data:

No	Parameter	Measurement channels
1	Consumed power	1
2	Pump rotor speed	1
3	Temperature of the driving unit	3
4	Liquid flow at inlet	1
5	Pressure in suction line	1
6	Temperature in suction line	1
7	Air flow before entering into the mixer	1
8	Air pressure before entering into the mixer	1
9	Suction chamber pressure	1
10	Elastomer temperature along the rotor-stator set	30
11	Pressure along the rotor-stator set	30
12	Outside temperature on the stator	3
13	Temperature on the discharge line	1
14	Pressure on the discharge line	1
16	Air pressure on the evacuation line from the tank	1
17	Air flow on the evacuation line from the tank	1

Progressive cavity pumps

Schematics of the liquid and liquid+air test bench

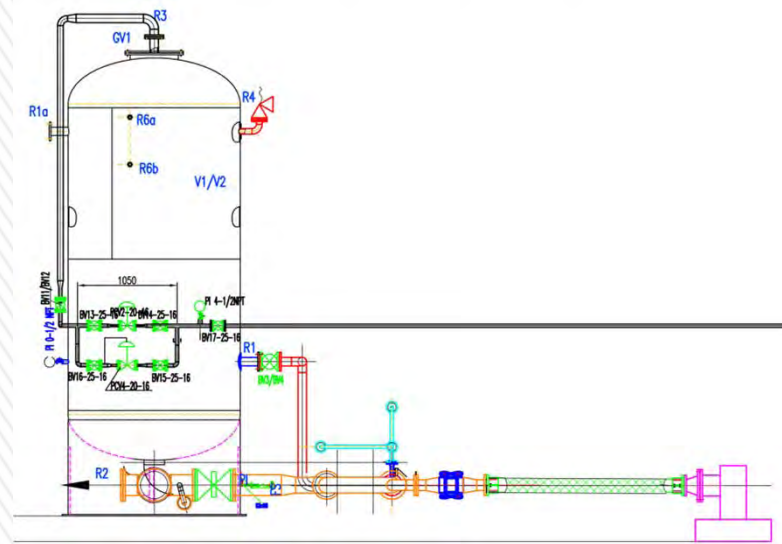
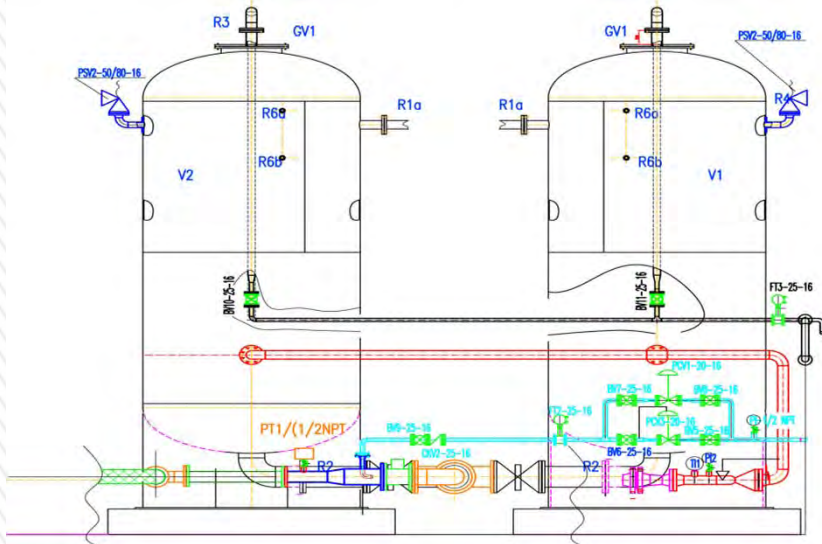
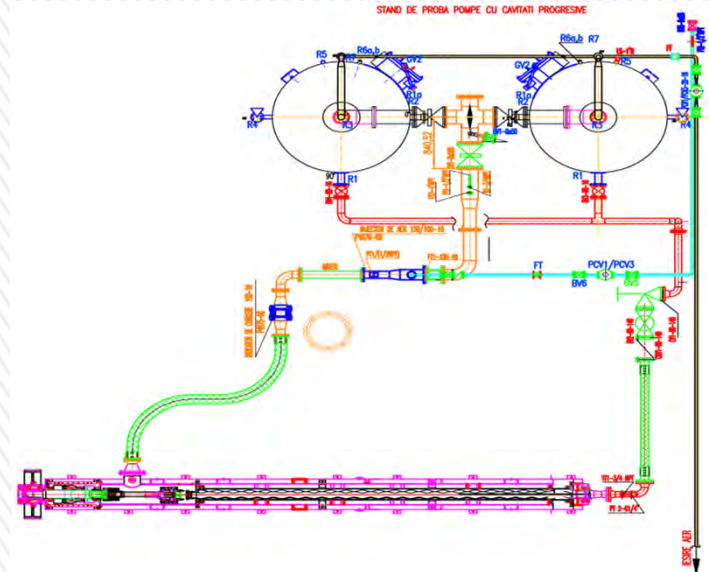
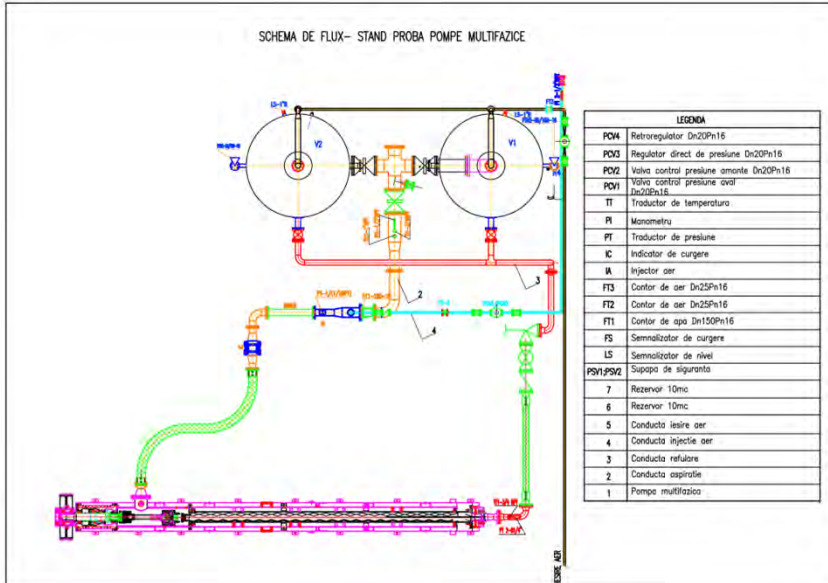

This document belongs to SC CONFIND srl and contains confidential information. Upon receipt of this document, the recipient accepts that this is a confidential document and has to be used solely for the purpose it has been received. The recipient will return this document to SC CONFIND srl upon request.

Progressive cavity pumps

Test bench control system structure

The automation system of the test bench for liquid nad multiphase pumps:

Instruments(mentioned above) for measuring pressure, temperature, flows, electric power etc

Interconnecting cables

Juction boxes: JB-001 (for temperature sensors), JB-002 (for pressure, flow sensors)

Control panel(DA), that includes a PLC PCD3.M5340 from Saia Burges and I/O modules

Computer with Saia VisiPlus software and the test bench application

Progressive cavity pumps

From software stand point, the system includes:

The application at the PLC level, that achieves:

Data acquisition (pressure, temperature, flow etc.) and local storage;

Control and protection of the tested pump;

Acoustic and visual signaling in case of reaching preset limits (missing liquid on the inlet, discharge pressure, tanks minimum liquid);

Control loops (electrically driven air injection valve, electrically driven air evacuation valve, electrically driven discharge valve);

The application at the computer level, that achieves:

User interface;

Communication with PLC in order to acquire data;

Data centralizing and storage in a file type .csv that can be seen as Excel;

Determination of alarm situations and presetting on screen;

Variation graphs of monitored parameters.

Progressive cavity pumps

Monitoring and presentation of parameters

Application allows selection of pump to be tested from a preset list (type, characteristics of flow and pressure on liquid):

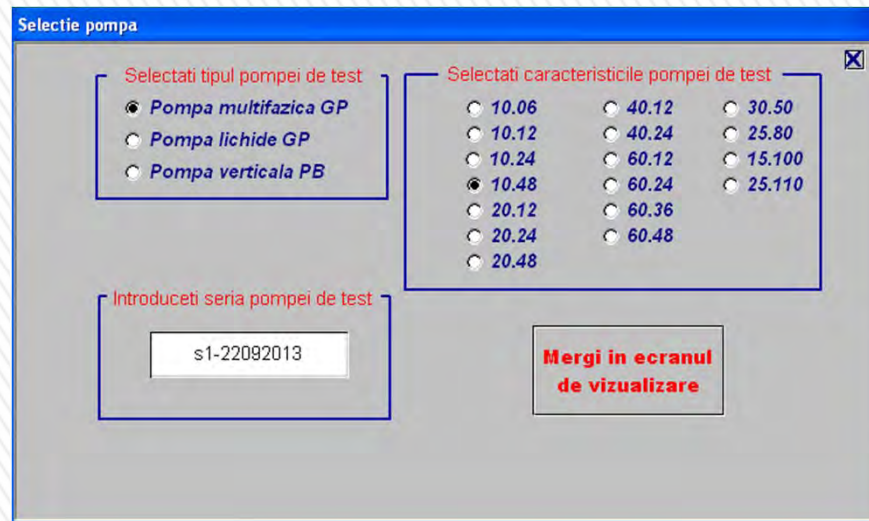

The screenshot shows a software window titled "Selectie pompa" with a close button in the top right corner. It contains three main sections:

- Selectati tipul pompei de test:** A list of radio buttons for pump types:
 - Pompa multifazica GP
 - Pompa lichide GP
 - Pompa verticala PB
- Selectati caracteristicile pompei de test:** A grid of radio buttons for pump characteristics:

<input type="radio"/> 10.06	<input type="radio"/> 40.12	<input type="radio"/> 30.50
<input type="radio"/> 10.12	<input type="radio"/> 40.24	<input type="radio"/> 25.80
<input type="radio"/> 10.24	<input type="radio"/> 60.12	<input type="radio"/> 15.100
<input checked="" type="radio"/> 10.48	<input type="radio"/> 60.24	<input type="radio"/> 25.110
<input type="radio"/> 20.12	<input type="radio"/> 60.36	
<input type="radio"/> 20.24	<input type="radio"/> 60.48	
<input type="radio"/> 20.48		
- Introduceti seria pompei de test:** A text input field containing the serial number "s1-22092013".

At the bottom right, there is a red button labeled "Mergi in ecranul de vizualizare".

After selecting the pump, measured values (instantaneous) for pressures, temperatures, flows are presented on specific screen depending on the pump type (liquid, multiphase, vertical). Data recording in file log*.csv (at defined intervals) begins upon pressing the button by the operator (button "Start test"); similarly, recording in file log*.csv is interrupted upon pressing the button by the operator (button "Stop test"). In file log*.csv there will be recorded: date, time, serial number of the tested pump, pump type, temperatures, pressures, flows, power, speed.

Progressive cavity pumps

The evolution of parameters in time can be seen in a graphic form. Unlike data recording, graphs are presented continuously.

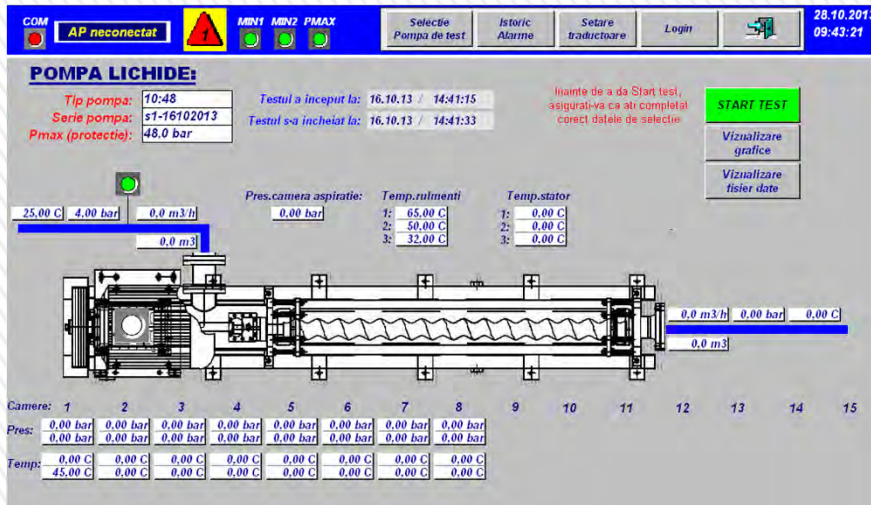

Application screen for liquid pump type

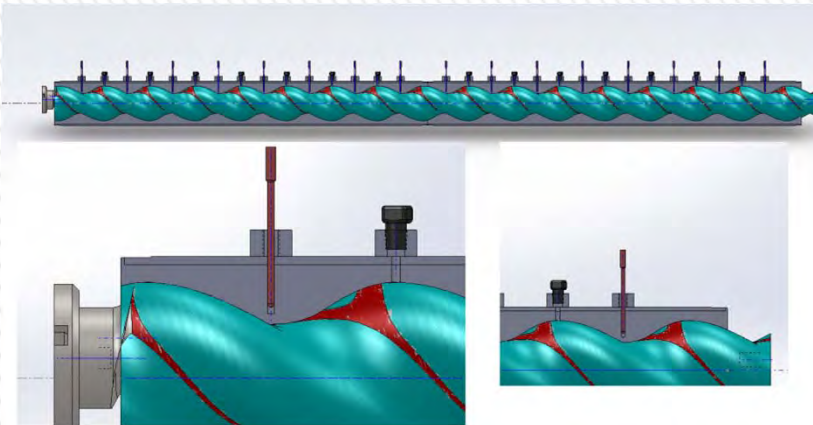

Multiphase pump equipped with pressure and temperature sensors

Progressive cavity pumps



Progressive cavity pumps

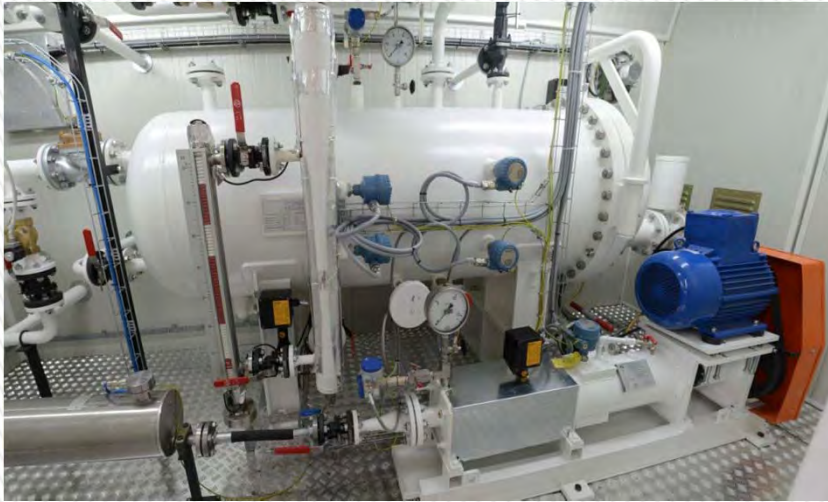

Progressive cavity pumps

